

Description of alternative and discontinued products

Mass-produced	Discontinued	Note
GH150E	MT4720TE	The 15" green series HMIs, which is the enhanced series, has more serial ports. Its installment size is different but hole dimension is same.
GH104E	MT4523TE	Same cutout size
GH070E	MT4424TE	Same cutout size
GH070	MT4404T	Same cutout size
GH043	MT4210T	Same cutout size
GH043E	MT4220TE	Same cutout size
G070	MT4414T	Same cutout size
G070E	MT4414TE	Same cutout size
G070E-CAN	MT4414TE-CAN	Same cutout size
G100E	MT4512T/MT4512TE	Same cutout size
G121E	MT4620TE	Same cutout size
GL150E		15" Economic type
GL104E	MT4513TE	Same cutout size
GL100E	MT4532TE	Same cutout size
GL100	MT4532T	Same cutout size
GL070E	MT4434TE	Same cutout size
GL070	MT4434T	Same cutout size
GL043E	MT4230TE	Same cutout size
GL043	MT4230T	Same cutout size

Mass-produced	Discontinued	Note
F080E	MT5423T MT4403T/MT4403TE	Same cutout size
F104E	MT5520T	Same cutout size
F104E-CAN	MT5520T-CAN	Same cutout size
F150E	MT5720T	Same cutout size
SZ7G	SZ7	Same overall dimension
SZ7GE	SZ7E	Same overall dimension
SZ7GS	SZ7S	Same overall dimension
SZ7GES	SZ7ES	Same overall dimension

GREEN/FUTURE/ MT4000 series communication cables

Communication cable mode	Description of cable
Green-Micro USB	USB download cable from computer to GREEN series (with Micro USB) HMI (with magnetic ring)
MT54-PC	Serial download cable from GREEN/FUTURE/ MT4000 series HMI to the computer (3 meters)
MT54-CQM-FEMALE	RS232 communication cable between GREEN/FUTURE/MT4000 series HMI and OMRON C series PLC (3 meters)
MT54-FX-F	RS422 communication cable between GREEN/FUTURE/MT4000 series HMI and Mitsubishi FX series PLC (3 meters)
MT54-KC-FEMALE	RS232 communication cable between GREEN/FUTURE/MT4000 series HMI and Kinco PLC (3 meters)
MT54-S7-200-FEMALE	RS485 communication cable between GREEN/FUTURE/MT4000 series HMI and S7-200 series PLC (3 meters)
MT54-Schneider-M218	RS232 communication cable between GREEN/FUTURE/MT4000 series HMI and Schneider PLC (3 meters)

- Tips: 1.For new projects, Kinco strongly suggest our customers to choose the Green series products and don't suggest to choose the MT4000 series.
2.The old projects in MT4000 series products can be opened directly in DTools. After simulation, they can downloaded to corresponding new type HMIs.

Kinco® Automation

<https://en.kinco.cn> Email:sales@kinco.cn

(All trademarks and logos in this brochure are property of and registered by their respective owners.)

Kinco

HMI
Touch Screen

Kinco HMI Catalog

- GREEN Series
- FUTURE Series
- Customized Series



K1E20-2108

GREEN Series Description

02 GREEN Series Description

Enhanced Type

- 06 GH043/GH043E
- 07 GH043U2/GH043EU2
- 08 GH070/GH070E
- 09 GH104E
- 10 GH150E

Economy Type

- 14 GL043/GL043E
- 15 GL070/GL070E
- 16 GL100/GL100E
- 17 GL104E
- 18 GL150E

Standard Type

- 11 G070/G070E/G070E-CAN
- 12 G100/G100E
- 13 G121E

IoT Type

- 19 GT070E/GT070E-4G/GT070E-WiFi
- 20 GT070HE/GT070HE-4G/GT070HE-WiFi
- 21 GT100E/GT100E-4G/GT100E-WiFi
- 22 GT100E2
- 23 GW01/GW01-4G/GW01-WiFi

FUTURE Series Description

24 FUTURE Series Description

FUTURE Series

- 25 F070E
- 26 F080E
- 27 F104E/F104E-CAN
- 28 F150E
- 29 xF-SiHMI01

Customized Series

- 30 Rear installation without front shell - GR Series : GR043 / GR070E / GR100E
- 31 Handheld Terminal : SZ7G/SZ7GS/SZ7GE/SZ7GES
- 32 Construction Machinery : CZ6/CZ10

34

Features of configuration software: DTools

Back cover

Description of alternative and discontinued products

Focusing on industrial human-machine interface for 19 years
we continue to provide high-quality products

The GREEN series is a new generation of industrial human machine interface. It adopts new architecture design, rigorous craft support, which makes it become paradigm in high-quality human machine interface.

The GREEN series adopts mainstream processor in the market. Not only does it ensure the product's life time, but also greatly improves the performance of the product.



Powerful hardware and software
More comprehensive upgrades

Structure

New structure
& exquisite body

Material Science

Higher hardness and
intensity; Higher
temperature resistance

Color

16.7M (24 bits)
true color
*Except for a few models

Kernel

Kernel, version upgrades,
more stable performance

CPU

CPU
Freescale industrial
class 800MHz

Memory

The memory
DDR3 is upgraded
to 128M

Kinco new generation of industrial HMI GREEN Series

The GREEN series products use the most advantageous ARM Cortex-A7 architecture industrial-grade processors, which ensure that HMIs efficiently work.

Kinco's smart factory, provides reliable guarantee for high-quality production in long-term.

GREEN Series contains multiple subseries:

GH series
Enhanced Type
4.3"-17"

- Up to 4 serial ports (excluding 4.3") , Ethernet
- Standard USB master port, slave port
- Built-in isolation power, serial port isolation (Ethernet model)
- Coating in mainboard

G series
Standard Type
7", 10", 12"

- 3 serial port, Ethernet
- Standard USB main port, slave port
- Built-in isolation power supply
- Coating in mainboard

GL series
Economic Type
4.3"-15"

- 2 serial port, Ethernet
- Standard USB master port, slave port (excluding 4.3")

GT/GW series
IoT Type
7", 10", Gateway

- WiFi, 4G, Ethernet

Kinco HMI Teleservice

- A value adding function for OEM

This dedicated teleservice is based on Kinco Edgeaccess Iot platform.

Advantages:

Easy to set up, Low cost, Reliable, High level data safety and No location limitation to access the machines.

Applications :

- HMI desktop access: Remotely monitor the machine in real time.
- Program update: Remotely download program to HMI and PLC program.
- Expert level Diagnosis: Remotely diagnose machine HMI and PLC program.
- Online update :Remotely update machine new recipe.

Support models:

- FUTURE series
- GREEN IoT GT series
- GREEN Gateway GW series
- GREEN Enhanced GH***E series
- GREEN Standard G***E series
- GREEN Economic GL***E series



Easily Connect with Alibaba Cloud IIoT Platform Help you to launch a new Industrial Internet Generation

The cloud IIoT solution of Green Series is able to help devices to connect with Cloud, and implement data transformation between device and cloud, device and device, and device to people.

- Monitor the operating status in real time
- Report Fault alarm instantly
- Data acquisition assists with data analysis , product optimization and pre maintenance
- Cost saving and no extra investment cost

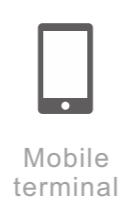
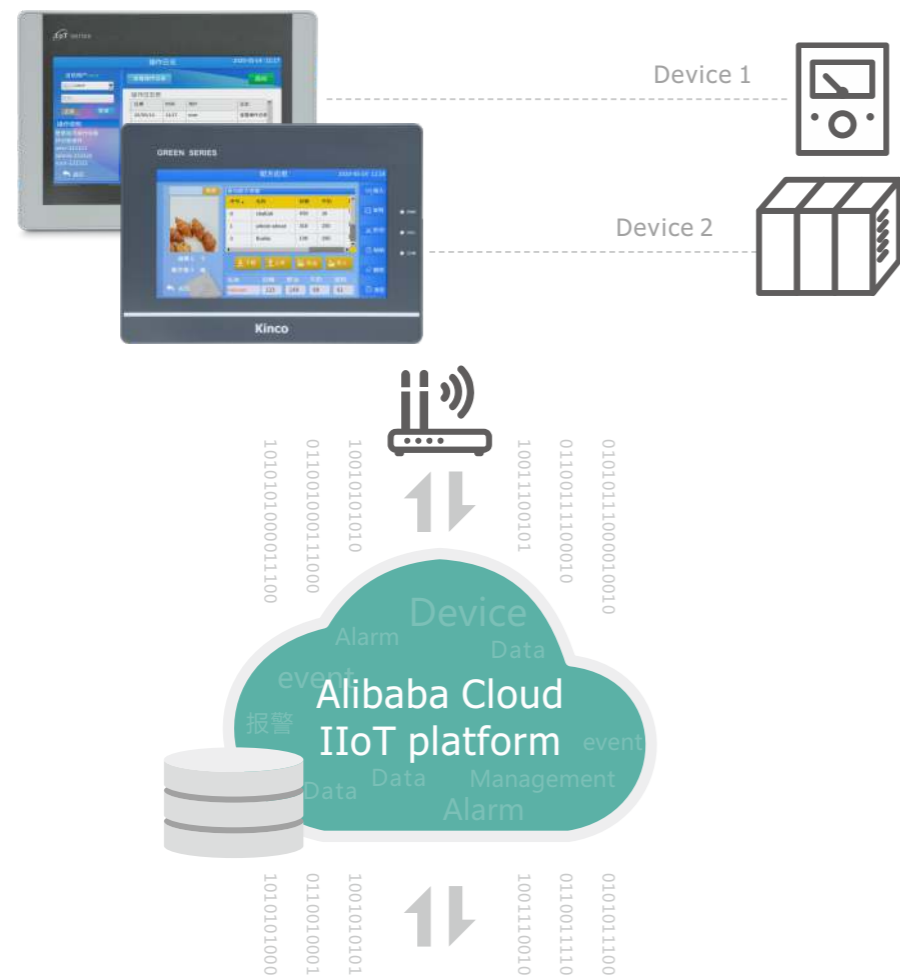

GH Series 4.3"

GH043/GH043E

- Preferred models for subway, high-speed railway and other rail transit.
- Main board Three-defence treatment to effectively deal with complex environment.
- Built-in isolation power to enhance reliability.
- Classic shape, hidden serial port outlet.



Model	GH043	GH043E
Performance specification		
Display size	4.3" TFT	
Display area	95.04mm(W)*53.86mm(H)	
Resolution	480*272 pixels	
Display color	16.7M true color	
Display angle of view	70/70/50/70(left/right/up/down)	
Contrast ratio	500:1	
Backlight	LED	
Brightness	300cd/m ²	
Backlight life	More than 30000 hours	
Touch panel	4 line precision resistance network (surface hardness 4H)	
CPU	ARM RISC 32Bit 800MHz	
Storage	128MB NAND Flash Memory+128MB DDR3 Memory	
RTC	Built-in	
Extensible memory	1 USB Host	1 USB Host + 1 SD Card
Print port	USB Host/serial port	USB Host/serial port
Ethernet	None	10/100M self-adaption
Program download	USB Slave(Type B)/U disk	USB Slave(Type B)/U disk/Ethernet
Communication port	COM0:RS232/RS485/RS422 COM2:RS232	COM0:RS232/RS485/RS422 COM2:RS232
Serial port isolation	None	None
Electrical specifications		
Input power supply	DC10.8V~DC28V, Built-in isolation power supply	
Rated power	3.5W @24V DC	
Allowable loss of power	<3ms	
Insulation resistance	Over 50MΩ@500V DC	
Hi-pot test	500 VAC 1 minute	
Structure specifications		
PCB	Exquisite spraying	
Shell material	Engineering plastic	
Shape size	154*89*60 mm	
Cutout size	146*81 mm	
Weight	0.4Kg	
Environmental specifications		
Operating ambient temperature	-20° C ~ 55° C	
Operating ambient humidity	10% to 90% noncondensing	
Storage ambient temperature	-25° C ~ 60° C	
Storage ambient humidity	10% to 90% noncondensing	
Sine vibration test	10~500Hz, 30m/s ² , X, Y, Z direction/hour	
Cooling mode	Natural air cooling	
Product certification		
Panel protection grade	Conforming to IP65 certification(4208-93)	
CE authentication	EN61000-6-4:2007+A1:2011, EN61000-6-2:2005	
Software		
Configuration software	Kinco DTools V3.3 and above	

Mechanical Dimensions (Unit:mm)

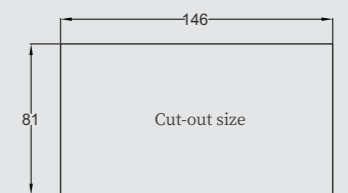
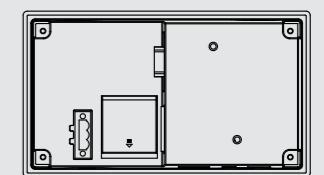
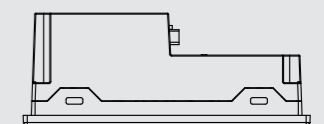
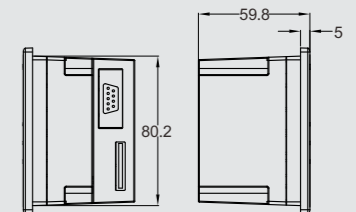
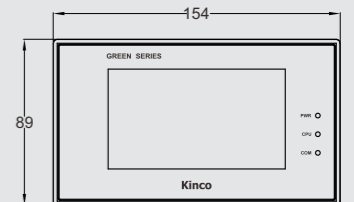
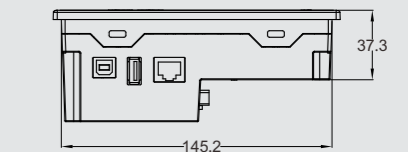

Note: GH043 is replacement of MT4210T. GH043E is replacement of MT4220TE.
Programming of MT4000 can be used for Green series HMI after edited by DTools.

* GREEN series models with Ethernet ports support this function.

GH Series 4.3"



GH043U2/GH043EU2

- Preferred models for subway, high-speed railway and other rail transit.
- Main board Three-denfence treatment to effectively deal with complex environment.
- Built-in isolation power to enhance reliability.
- Dual USB Host, front and rear can be connected to USB devices or U disk.

Model	GH043U2	GH043EU2
Performance specification		
Display size	4.3"TFT	
Display area	95.04mm(W)*53.86mm(H)	
Resolution	480*272 pixels	
Display color	16.7M true color	
Display angle of view	70/70/50/70(left/right/up/down)	
Contrast ratio	500:1	
Backlight	LED	
Brightness	300cd/m ²	
Backlight life	More than 30000 hours	
Touch panel	4 line precision resistance network (surface hardness 4H)	
CPU	ARM RISC 32Bit 800MHz	
Storage	128MB NAND Flash Memory+128MB DDR3 Memory	
RTC	Built-in	
Extensible memory	2 USB Host	2 USB Host + 1 SD Card
Print port	USB Host*2/serial port	USB Host*2/serial port
Ethernet	None	10/100M self-adaption
Program download	USB Slave(Type B)/U disk	USB Slave(Type B)/U disk/Ethernet
Communication port	COM0:RS232/RS485/RS422 COM2:RS232	COM0:RS232/RS485/RS422 COM2:RS232
Serial port isolation	None	None
Electrical specifications		
Input power supply	DC10.8V~DC28V, Built-in isolation power supply	
Rated power	3.5W @24V DC	
Allowable loss of power	<3ms	
Insulation resistance	Over 50MΩ@500V DC	
Hi-pot test	500 VAC 1 minute	
Structure specifications		
PCB	Exquisite spraying	
Shell material	Engineering plastic	
Shape size	154*89*60 mm	
Cutout size	146*81 mm	
Weight	0.4Kg	
Environmental specifications		
Operating ambient temperature	-25° C ~ 55° C	
Operating ambient humidity	10% to 90% noncondensing	
Storage ambient temperature	-25° C ~ 60° C	
Storage ambient humidity	10% to 90% noncondensing	
Sine vibration test	10~500Hz, 30m/s ² , X, Y, Z direction/hour	
Cooling mode	Natural air cooling	
Product certification		
Panel protection grade	Conforming to IP65 certification(4208-93)	
CE authentication	EN61000-6-4:2007+A1:2011, EN61000-6-2:2005	
Software		
Configuration software	Kinco DTools V3.3 and above	

Mechanical Dimensions (Unit:mm)

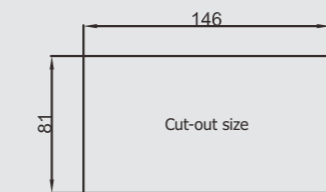
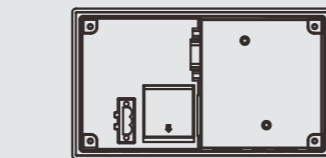
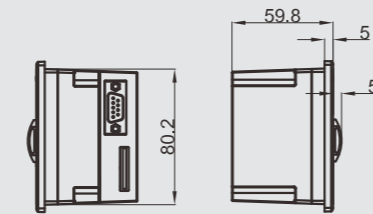
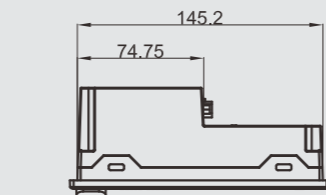
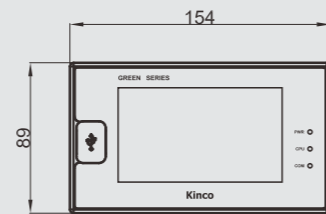
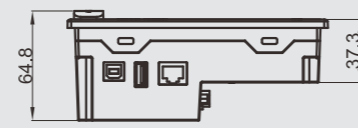

GH Series 7"



GH070/GH070E

- Suitable for high reliability expected situations
- Three anti - spraying + multiple isolation more reliable
- Up to four serial port +SD card expansion
- Artistically ultra-narrow border

Model	GH070	GH070E
Performance specification		
Display size	7"TFT	
Display area	154.08mm(W)*85.92mm(H)	
Resolution	800*480 pixels	
Display color	16.7M true color	
Display angle of view	70/70/50/70(left/right/up/down)	
Contrast ratio	500:1	
Backlight	LED	
Brightness	400cd/m ²	
Backlight life	More than 30000 hours	
Touch panel	4 line precision resistance network (surface hardness 4H)	
CPU	ARM RISC 32Bit 800MHz	
Storage	128MB NAND Flash Memory+128MB DDR3 Memory	
RTC	Built-in	
Extensible memory	1 USB Host	1 USB Host + 1 SD Card
Print port	USB Host/serial port	USB Host/serial port
Ethernet	None	10/100M self-adaption
Program download	USB Slave(Type B)/U disk	USB Slave(Type B)/U disk/Ethernet
Communication port	COM0:RS232/RS485/RS422 COM1:RS232/RS485/RS422 COM2:RS232, COM3:RS485	
Serial port isolation	None	Built-in
Electrical specifications		
Input power supply	DC12V~DC28V,Built-in isolation power supply	
Rated power	5W @24V DC	
Allowable loss of power	<3ms	
Insulation resistance	Over 50MΩ@500V DC	
Hi-pot test	500 VAC 1 minute	
Structure specifications		
PCB	Exquisite spraying	
Shell material	Engineering plastic	
Shape size	207*125*41 mm	
Cutout size	194*113 mm	
Weight	0.6Kg	
Environmental specifications		
Operating ambient temperature	-10° C ~ 55° C	
Operating ambient humidity	10% to 90% noncondensing	
Storage ambient temperature	-20° C ~ 60° C	
Storage ambient humidity	10% to 90% noncondensing	
Sine vibration test	10~500Hz, 30m/s ² , X, Y, Z direction/hour	
Cooling mode	Natural air cooling	
Product certification		
Panel protection grade	Conforming to IP65 certification(4208-93)	
CE authentication	EN61000-6-4:2007+A1:2011, EN61000-6-2:2005	
Software		
Configuration software	Kinco DTools V3.3 and above	

Mechanical Dimensions (Unit:mm)

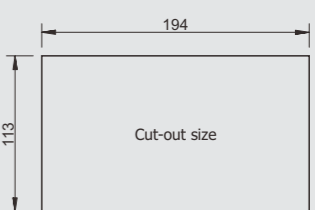
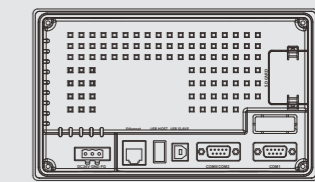
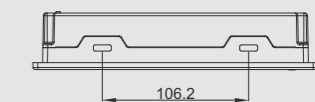
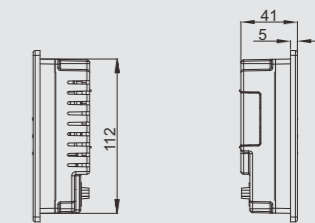
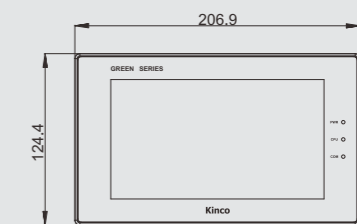
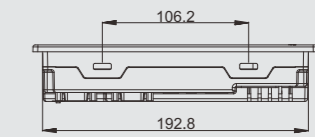

Note: GH070 is replacement of MT4404T, GH070E is replacement of MT4424TE.
Programming of MT4000 can be used for Green series HMI after edited by DTools.

GH Series 10.4"

GH104E

- Suitable for high reliability expected situations
- Three anti - spraying + multiple isolation more reliable
- Up to four serial port +SD card expansion
- Industrial screen ratio 4:3, display area is 20% higher than the wide-screen



Model	GH104E
Performance specification	
Display size	10.4"TFT
Display area	211.20mm(W)*158.40mm(H)
Resolution	800*600 pixel
Display color	16.7M true color
Display angle of view	70/70/60/70(left/right/up/down)
Contrast ratio	500:1
Backlight	LED
Brightness	350cd/m ²
Backlight life	More than 30000 hours
Touch panel	4 line precision resistance network (surface hardness 4H)
CPU	ARM RISC 32Bit 800MHz
Storage	128MB NAND Flash Memory+128MB DDR3 Memory
RTC	Built-in
Extensible memory	1 USB Host + 1 SD Card
Print port	USB Host/serial port
Ethernet	10/100M self-adaption
Program download	USB Slave(Type B)/U disk/Ethernet
Communication port	COM0:RS232/RS485/RS422 COM1: RS232/RS485/RS422 COM2:RS232, COM3: RS485
Serial port isolation	Built-in
Electrical specifications	
Input power supply	DC10.8V~DC28V, Built-in isolation power supply
Rated power	8W @24V DC
Allowable loss of power	<3ms
Insulation resistance	Over 50MΩ@500V DC
Hi-pot test	500 VAC 1 minute
Structure specifications	
PCB	Exquisite spraying
Shell material	Engineering plastic
Shape size	310*230*56 mm
Cutout size	299*219 mm
Weight	1.715Kg
Environmental specifications	
Operating ambient temperature	-10° C ~ 55° C
Operating ambient humidity	10% to 90% noncondensing
Storage ambient temperature	-20° C ~ 60° C
Storage ambient humidity	10% to 90% noncondensing
Sine vibration test	10~500Hz, 30m/s ² , X, Y, Z direction/hour
Cooling mode	Natural air cooling
Product certification	
Panel protection grade	Conforming to IP65 certification(4208-93)
CE authentication	EN61000-6-4:2007+A1:2011, EN61000-6-2:2005
Software	
Configuration software	Kinco DTools V3.3 and above

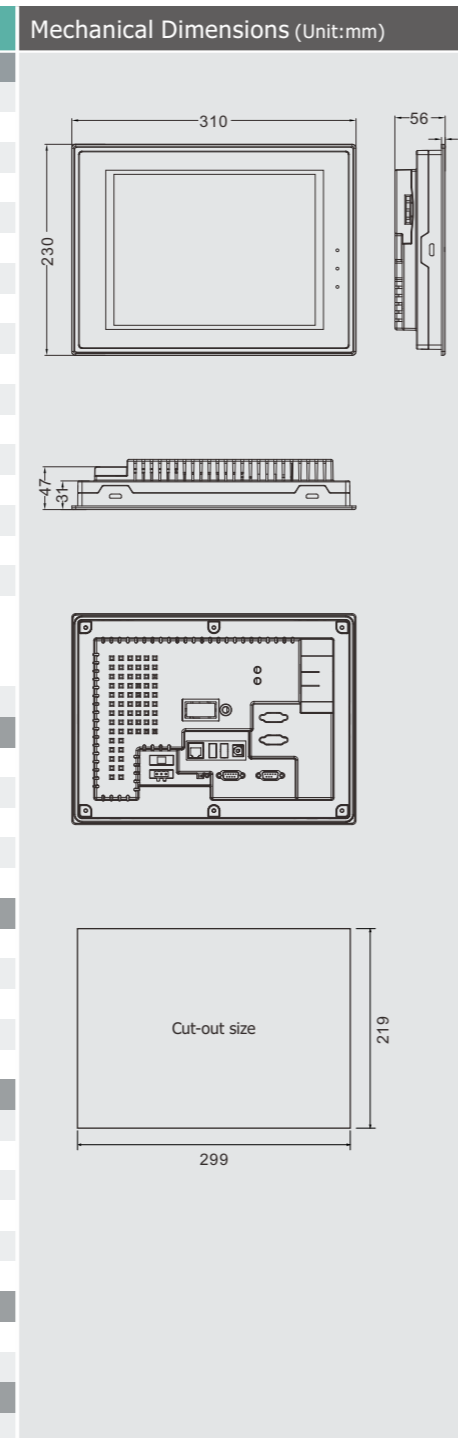

Note: GH104E is replacement of MT4523TE.
Programming of MT4000 can be used for Green series HMI after edited by DTools.

GH Series 15"

GH150E

- It is suitable for high reliability expected situations
- Three anti - spraying + multiple isolation more reliable
- Up to four serial port +SD card expansion
- Fashion design, graceful and decent



Model	GH150E
Performance specification	
Display size	15"TFT
Display area	304.13mm(W)*228.10mm(H)
Resolution	1024*768 pixels
Display color	65536 color
Display angle of view	80/80/80/80(left/right/up/down)
Contrast ratio	800:1
Backlight	LED
Brightness	420cd/m ²
Backlight life	50000 hours
Touch panel	4 line precision resistance network (surface hardness 4H)
CPU	ARM RISC 32Bit 800MHz
Storage	128MB NAND Flash Memory+128MB DDR3 Memory
RTC	Built-in
Extensible memory	1 USB Host + 1 SD Card
Print port	USB Host/serial port
Ethernet	10/100M self-adaption
Program download	USB Slave(Micro USB)/U disk/Ethernet
Communication port	COM0:RS232/RS485/RS422 COM1:RS232/RS485/RS422 COM2:RS232, COM3:RS485
Serial port isolation	Built-in
Electrical specifications	
Input power supply	DC10.8V~DC28V,Built-in isolation power supply
Rated power	16W @24V DC
Allowable loss of power	<3ms
Insulation resistance	Over 50MΩ@500V DC
Hi-pot test	500 VAC 1 minute
Structure specifications	
PCB	Exquisite spraying
Shell material	Engineering plastic
Shape size	398*298*47 mm
Cutout size	383*283 mm
Weight	3Kg
Environmental specifications	
Operating ambient temperature	-10° C ~ 55° C
Operating ambient humidity	10% to 90% noncondensing
Storage ambient temperature	-20° C ~ 60° C
Storage ambient humidity	10% to 90% noncondensing
Sine vibration test	10~500Hz, 30m/s ² , X, Y, Z direction/hour
Cooling mode	Natural air cooling
Product certification	
Panel protection grade	Conforming to IP65 certification(4208-93)
CE authentication	EN61000-6-4:2007+A1:2011, EN61000-6-2:2005
Software	
Configuration software	Kinco DTools V3.3 and above

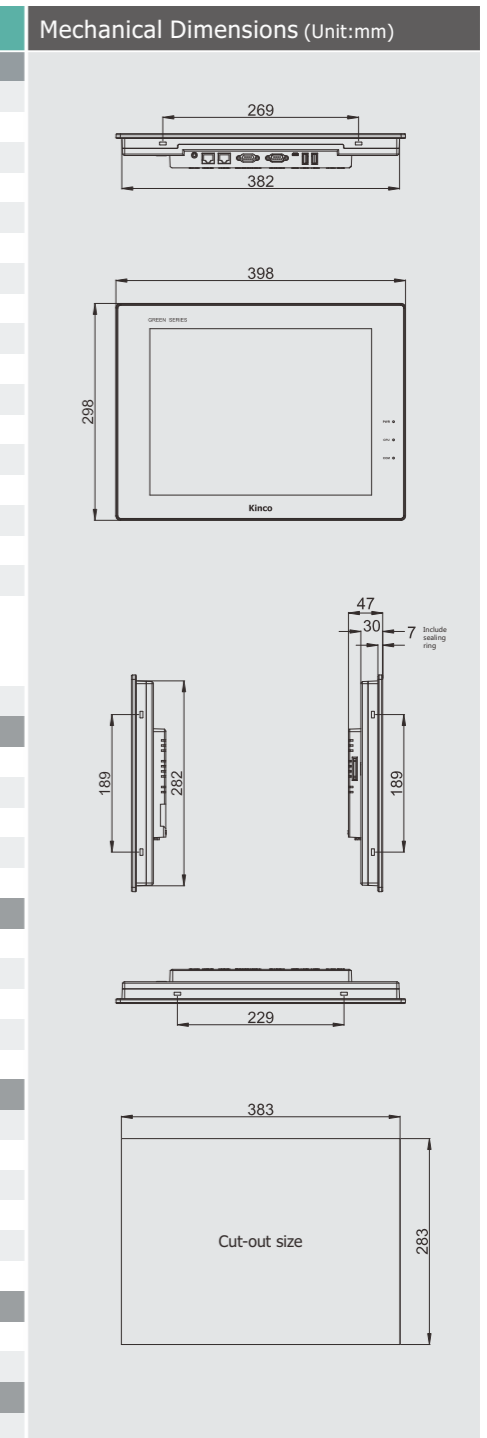

Note: GH150E is replacement of MT4720TE.
Programming of MT4000 can be used for Green series HMI after edited by DTools.

Standard Type

G Series

7"



G070/G070E/G070E-CAN

- Three anti-spraying + built-in isolation power to enhance reliability
- High brightness liquid crystal provide better display effect
- CAN port is supported
- Three series ports meet diverse needs

Model	G070	G070E	G070E-CAN
Performance specification			
Display size	7" TFT		
Display area	154.08mm(W)*85.92mm(H)		
Resolution	800*480 pixels		
Display color	16.7M true color		
Display angle of view	70/70/60/70(left/right/up/down)		
Contrast ratio	500:1		
Backlight	LED		
Brightness	400cd/m ²		
Backlight life	More than 30000 hours		
Touch panel	4 line precision resistance network (surface hardness 4H)		
CPU	ARM RISC 32Bit 800MHz		
Storage	128MB NAND Flash Memory+128MB DDR3 Memory		
RTC	Built-in		
Extensible memory	1 USB Host		
Print port	USB Host/serial port		
Ethernet	None	10/100M self-adaption	
Bus interface	None	None	1*CANopen
Program download	USB Slave(Micro USB)/U disk	USB Slave(Micro USB)/U disk/Ethernet	
Communication port	COM0:RS232/RS485/RS422 COM1:RS485/RS422 COM2:RS232		
Electrical specifications			
Input power supply	DC12V~DC28V, Built-in isolation power supply		
Rated power	3.8W @24V DC		
Allowable loss of power	<3ms		
Insulation resistance	Over 50MΩ@500V DC		
Hi-pot test	500 VAC 1 minute		
Structure specifications			
PCB	Exquisite spraying		
Shell material	Engineering plastic		
Shape size	204*150*37 mm		
Cutout size	192*138 mm		
Weight	0.5Kg		
Environmental specifications			
Operating ambient temperature	0° C ~ 50° C		
Operating ambient humidity	10% to 90% noncondensing		
Storage ambient temperature	-20° C ~ 60° C		
Storage ambient humidity	10% to 90% noncondensing		
Sine vibration test	10~500Hz, 30m/s ² , X, Y, Z direction/hour		
Cooling mode	Natural air cooling		
Product certification			
Panel protection grade	Conforming to IP65 certification(4208-93)		
CE authentication	EN61000-6-4:2007+A1:2011, EN61000-6-2:2005		
Software			
Configuration software	Kinco DTools V3.3 and above		

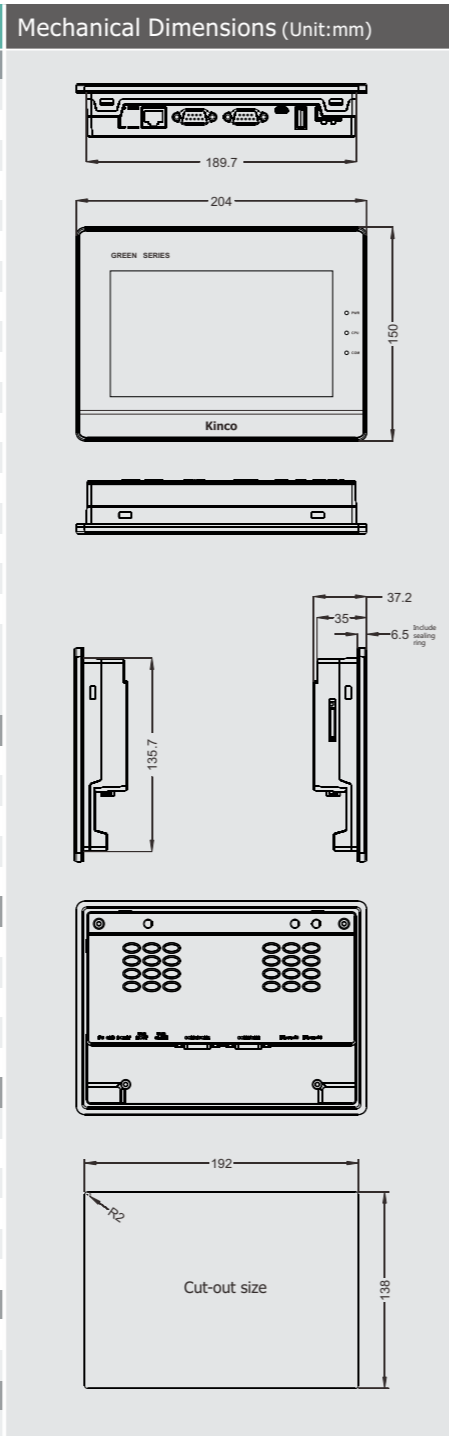

Note: G070 is replacement of MT4414T, G070E is replacement of MT4414TE, G070E-CAN is replacement of MT4414TE-CAN. Programming of MT4000 can be used for Green series HMI after edited by DTools.

Standard Type

G Series

10.1"



G100/G100E

- Preferred model in food industry
- Three anti-spraying + built-in isolation power to enhance reliability
- Three series ports meet diverse needs
- 1024*600 high resolution to meet various needs

Model	G100	G100E
Performance specification		
Display size	10.1" TFT	
Display area	222.72mm(W)*125.28mm(H)	
Resolution	1024*600 pixels	
Display color	16.7M true color	
Display angle of view	75/75/60/60(left/right/up/down)	
Contrast ratio	500:1	
Backlight	LED	
Brightness	350cd/m ²	
Backlight life	More than 30000 hours	
Touch panel	4 line precision resistance network (surface hardness 4H)	
CPU	ARM RISC 32Bit 800MHz	
Storage	128MB NAND Flash Memory+128MB DDR3 Memory	
RTC	Built-in	
Extensible memory	1 USB Host	
Print port	USB Host/serial port	
Ethernet	None	10/100M self-adaption
Program download	U disk	U disk/Ethernet
Communication port	COM0:RS232/RS485/RS422 COM1:RS485/RS422 COM2:RS232	
Electrical specifications		
Input power supply	DC10.8V~DC28V, Built-in isolation power supply	
Rated power	6W @24V DC	
Allowable loss of power	<3ms	
Insulation resistance	Over 50MΩ@500V DC	
Hi-pot test	500 VAC 1 minute	
Structure specifications		
PCB	Exquisite spraying	
Shell material	Engineering plastic	
Shape size	310*230*55 mm	
Cutout size	299*219 mm	
Weight	1.8Kg	
Environmental specifications		
Operating ambient temperature	-10° C ~ 50° C	
Operating ambient humidity	10% to 90% noncondensing	
Storage ambient temperature	-20° C ~ 60° C	
Storage ambient humidity	10% to 90% noncondensing	
Sine vibration test	10~500Hz, 30m/s ² , X, Y, Z direction/hour	
Cooling mode	Natural air cooling	
Product certification		
Panel protection grade	Conforming to IP65 certification(4208-93)	
CE authentication	EN61000-6-4:2007+A1:2011, EN61000-6-2:2005	
Software		
Configuration software	Kinco DTools V3.4 and above	

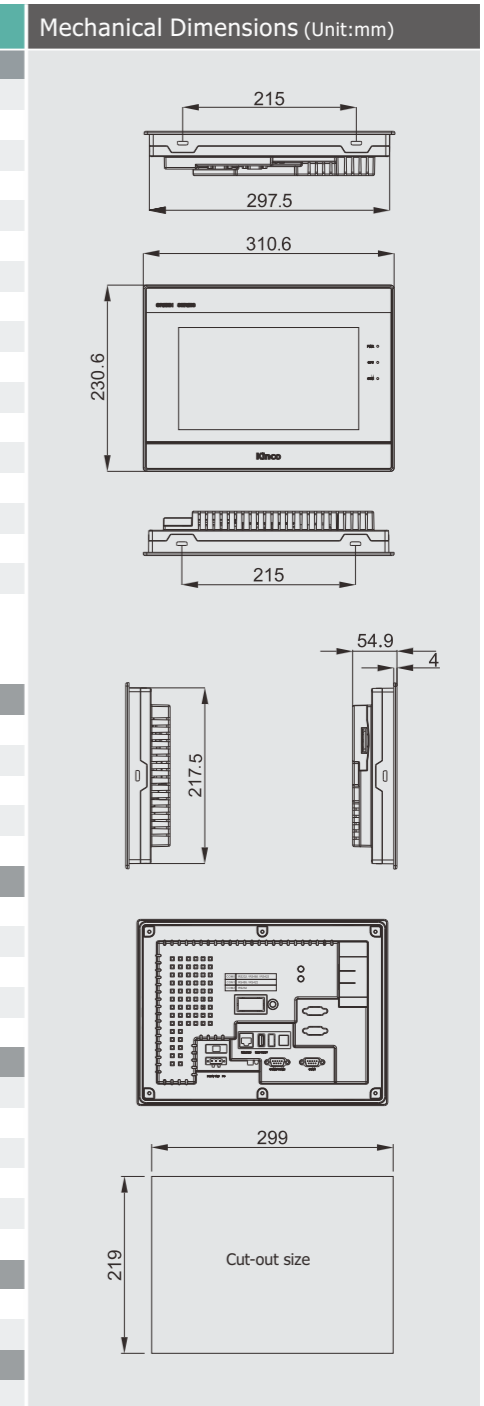

Note: G100 is replacement of MT4512T, G100E is replacement of MT4512TE. Programming of MT4000 can be used for Green series HMI after edited by DTools.

Standard Type

G Series 12.1"



G121E

- Advanced platform : NXP industrial-grade CPU, supply more than 10 years
- industrial display : 12.1", 4:3 ratio, provides bigger display area, highlights, and clarity
- Rich in storage : support external SD card, usb flash drive, up to 256GB
- Perfect protection : built-in serial port isolation, power supply, enhance reliability

Model	G121E
Performance specification	
Display size	12.1"TFT
Display area	246mm(W)*184.5mm(H)
Resolution	800*600 pixels
Display color	65535 color
Display angle of view	80/80/65/75(left/right/up/down)
Contrast ratio	800:1
Backlight	LED
Brightness	400cd/m ²
Backlight life	50000 hours
Touch panel	4 line precision resistance network (surface hardness 4H)
CPU	ARM RISC 32Bit 800MHz
Storage	128MB NAND Flash Memory+128MB DDR3 Memory
RTC	Built-in
Extensible memory	1 USB Host + 1 SD Card
Print port	USB Host/serial port
Ethernet	10/100M self-adaption
Program download	USB Slave(Micro USB)/U disk/Ethernet
Communication port	COM0:RS232/RS485/RS422 COM1:RS485/RS422 COM2:RS232
Electrical specifications	
Input power supply	DC12V~DC28V, Built-in isolation power supply
Rated power	10.8W @24V DC
Allowable loss of power	<3ms
Insulation resistance	Over 50MΩ@500V DC
Hi-pot test	500 VAC 1 minute
Structure specifications	
PCB	Exquisite spraying
Shell material	Engineering plastic
Shape size	350*260*54 mm
Cutout size	340*250 mm
Weight	2.2Kg
Environmental specifications	
Operating ambient temperature	-10° C ~ 55° C
Operating ambient humidity	10% to 90% noncondensing
Storage ambient temperature	-20° C ~ 60° C
Storage ambient humidity	10% to 90% noncondensing
Sine vibration test	10~500Hz, 30m/s ² , X, Y, Z direction/hour
Cooling mode	Natural air cooling
Product certification	
Panel protection grade	Conforming to IP65 certification(4208-93)
CE authentication	EN61000-6-4:2007+A1:2011, EN61000-6-2:2005
Software	
Configuration software	Kinco DTools V3.4 and above

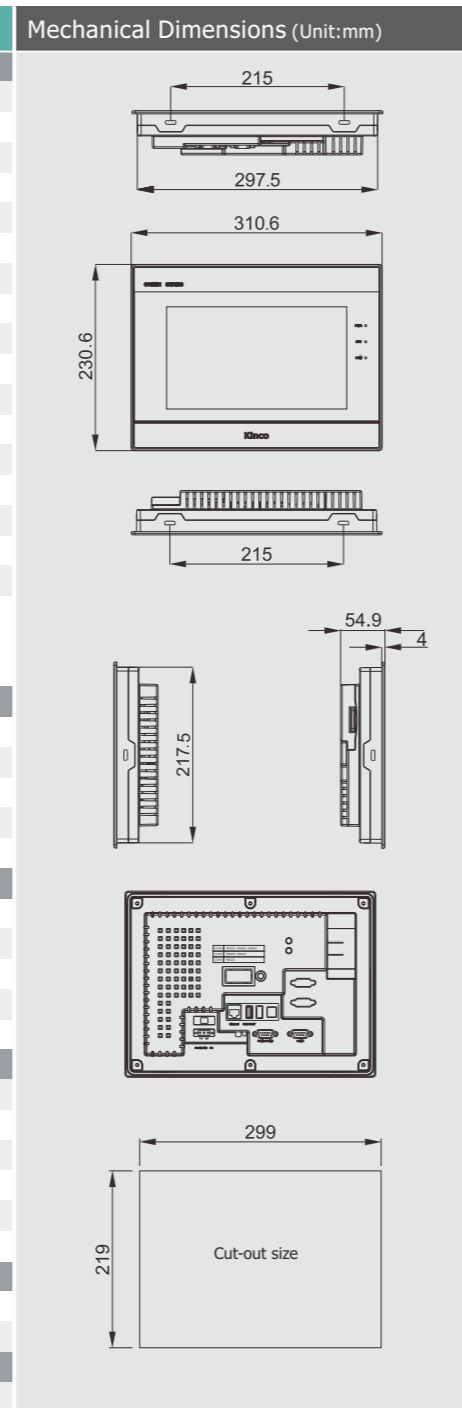

Note: G121E is replacement of MT4620TE.
Programming of MT4000 can be used for Green series HMI after edited by DTools.

Economy Type

GL Series 4.3"



GL043/GL043E

- Suitable for small space occasions
- Beautiful appearance, ultra-thin body
- High cost-effective

Model	GL043	GL043E
Performance specification		
Display size	4.3"TFT	
Display area	95.04mm(W)*53.86mm(H)	
Resolution	480*272 pixels	
Display color	16.7M true color	
Display angle of view	70/70/50/70(left/right/up/down)	
Contrast ratio	500:1	
Backlight	LED	
Brightness	450cd/m ²	
Backlight life	More than 30000 hours	
Touch panel	4 line precision resistance network (surface hardness 4H)	
CPU	ARM RISC 32Bit 800MHz	
Storage	128MB NAND Flash Memory+128MB DDR3 Memory	
RTC	Built-in	
Extensible memory	None	
Print port	Serial port	
Ethernet	None	10/100M self-adaption
Program download	USB Slave(Micro USB)/Serial port	USB Slave(Micro USB)/Serial port/Ethernet
Communication port	COM0:RS232/RS485/RS422 COM2:RS232	
Electrical specifications		
Input power supply	DC10V~DC28V, Built-in isolation power supply	
Rated power	2W @24V DC	
Allowable loss of power	<3ms	
Insulation resistance	Over 50MΩ@500V DC	
Hi-pot test	500 VAC 1 minute	
Structure specifications		
PCB	None of spraying	
Shell material	Engineering plastic	
Shape size	132*102*33 mm	
Cutout size	119*93 mm	
Weight	0.21Kg	
Environmental specifications		
Operating ambient temperature	0° C ~ 50° C	
Operating ambient humidity	10% to 90% noncondensing	
Storage ambient temperature	-20° C ~ 60° C	
Storage ambient humidity	10% to 90% noncondensing	
Sine vibration test	10~500Hz, 30m/s ² , X, Y, Z direction/hour	
Cooling mode	Natural air cooling	
Product certification		
Panel protection grade	Conforming to IP65 certification(4208-93)	
CE authentication	EN61000-6-4:2007+A1:2011, EN61000-6-2:2005	
Software		
Configuration software	Kinco DTools V3.3 and above	

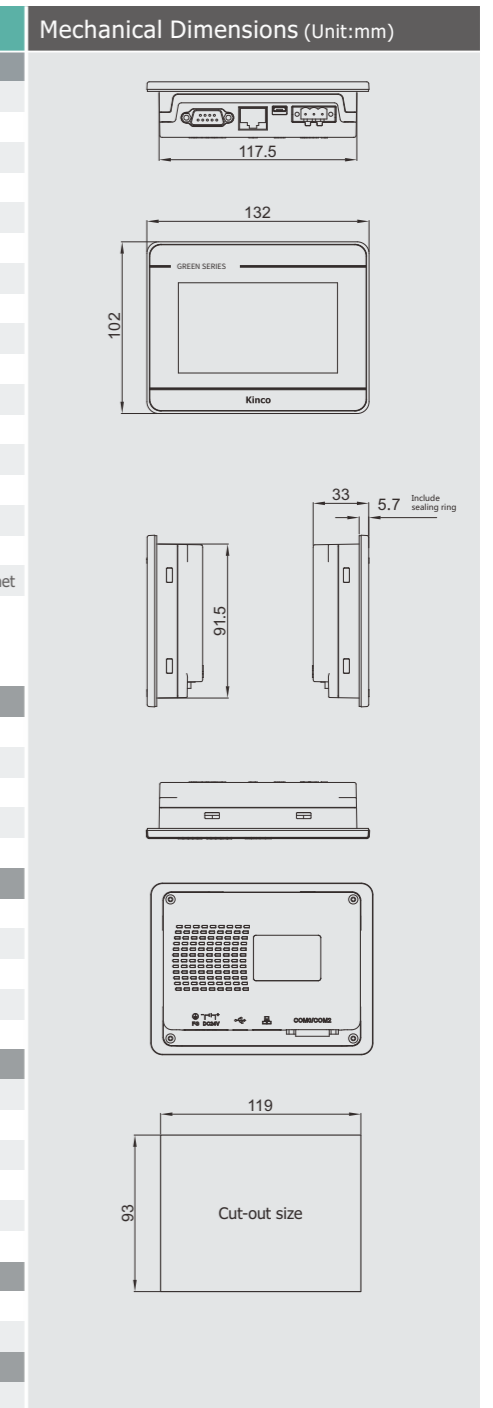

Note: GL043 is replacement of MT4230T. GL043E is replacement of MT4230TE.
Programming of MT4000 can be used for Green series HMI after edited by DTools.

GL Series 7"



GL070/GL070E

- Preferred model for general use
- A non-hollow mask is more effective against oil pollution
- Beautiful appearance, ultra-thin body
- High cost-effective

Model	GL070	GL070E
Performance specification		
Display size	7"TFT	
Display area	154.08mm(W)*85.92mm(H)	
Resolution	800*480 pixels	
Display color	16.7M true color	
Display angle of view	70/70/50/70(left/right/up/down)	
Contrast ratio	500:1	
Backlight	LED	
Brightness	250cd/m ²	
Backlight life	More than 30000 hours	
Touch panel	4 line precision resistance network (surface hardness 4H)	
CPU	ARM RISC 32Bit 800MHz	
Storage	128MB NAND Flash Memory+128MB DDR3 Memory	
RTC	Built-in	
Extensible memory	1 USB Host	
Print port	USB Host/Serial port	
Ethernet	None	10/100M self-adaption
Program download	USB Slave(Micro USB)/U disk	USB Slave(Micro USB)/U disk/Ethernet
Communication port	COM0:RS232/RS485/RS422 COM2:RS232	
Electrical specifications		
Input power supply	DC10V~DC28V	
Rated power	3.6W @24V DC	
Allowable loss of power	<3ms	
Insulation resistance	Over 50MΩ@500V DC	
Hi-pot test	500 VAC 1 minute	
Structure specifications		
PCB	None of spraying	
Shell material	Engineering plastic	
Shape size	204*150*37 mm	
Cutout size	192*138 mm	
Weight	0.5Kg	
Environmental specifications		
Operating ambient temperature	0° C ~ 50° C	
Operating ambient humidity	10% to 90% noncondensing	
Storage ambient temperature	-20° C ~ 60° C	
Storage ambient humidity	10% to 90% noncondensing	
Sine vibration test	10~500Hz, 30m/s ² , X, Y, Z direction/hour	
Cooling mode	Natural air cooling	
Product certification		
Panel protection grade	Conforming to IP65 certification(4208-93)	
CE authentication	EN61000-6-4:2007+A1:2011, EN61000-6-2:2005	
Software		
Configuration software	Kinco DTools V3.3 and above	

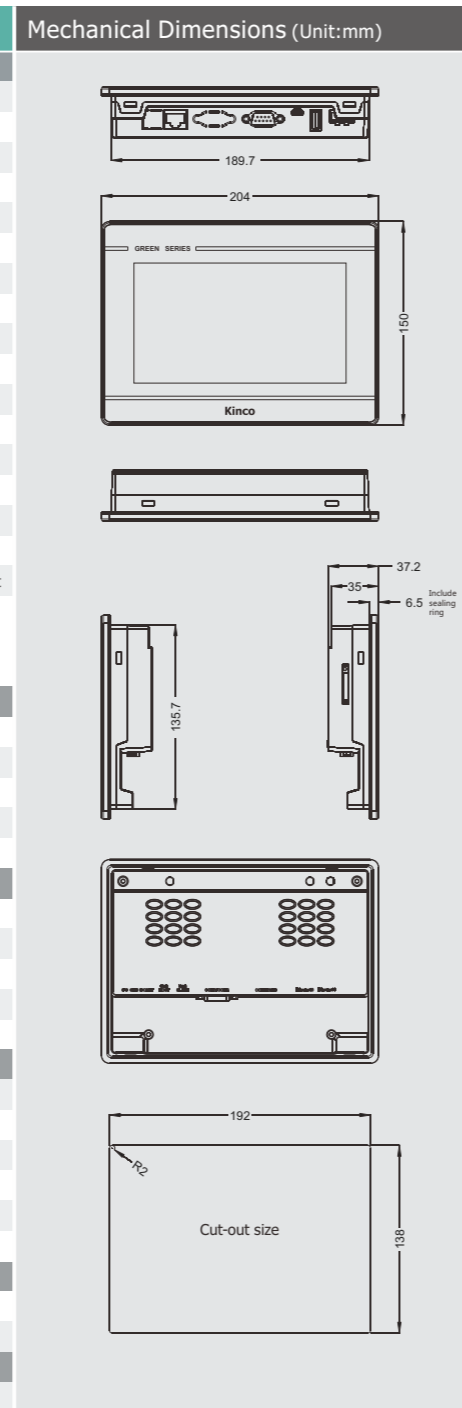

Note: GL070 is replacement of MT4434T. GL070E is replacement of MT4434TE.
Programming of MT4000 can be used for Green series HMI after edited by DTools.

GL Series 10.1"



GL100/GL100E

- Preferred model for general use
- A non-hollow mask is more effective against oil pollution
- Beautiful appearance, ultra-thin body
- High cost-effective

Model	GL100	GL100E
Performance specification		
Display size	10.1"TFT	
Display area	222.72mm(W)*125.28mm(H)	
Resolution	1024*600 pixels	
Display color	16.7M true color	
Display angle of view	70/70/60/70(left/right/up/down)	
Contrast ratio	500:1	
Backlight	LED	
Brightness	400cd/m ²	
Backlight life	More than 30000 hours	
Touch panel	4 line precision resistance network (surface hardness 4H)	
CPU	ARM RISC 32Bit 800MHz	
Storage	128MB NAND Flash Memory+128MB DDR3 Memory	
RTC	Built-in	
Extensible memory	1 USB Host	
Print port	USB Host/Serial port	
Ethernet	None	10/100M self-adaption
Program download	USB Slave(Micro USB)/U disk	USB Slave(Micro USB)/U disk/Ethernet
Communication port	COM0:RS232/RS485/RS422 COM2:RS232	
Electrical specifications		
Input power supply	DC10V~DC28V	
Rated power	6W @24V DC	
Allowable loss of power	<3ms	
Insulation resistance	Over 50MΩ@500V DC	
Hi-pot test	500 VAC 1 minute	
Structure specifications		
PCB	None of spraying	
Shell material	Engineering plastic	
Shape size	280*193*36 mm	
Cutout size	261*180 mm	
Weight	0.9Kg	
Environmental specifications		
Operating ambient temperature	0° C ~ 50° C	
Operating ambient humidity	10% to 90% noncondensing	
Storage ambient temperature	-20° C ~ 60° C	
Storage ambient humidity	10% to 90% noncondensing	
Sine vibration test	10~500Hz, 30m/s ² , X, Y, Z direction/hour	
Cooling mode	Natural air cooling	
Product certification		
Panel protection grade	Conforming to IP65 certification(4208-93)	
CE authentication	EN61000-6-4:2007+A1:2011, EN61000-6-2:2005	
Software		
Configuration software	Kinco DTools V3.3 and above	

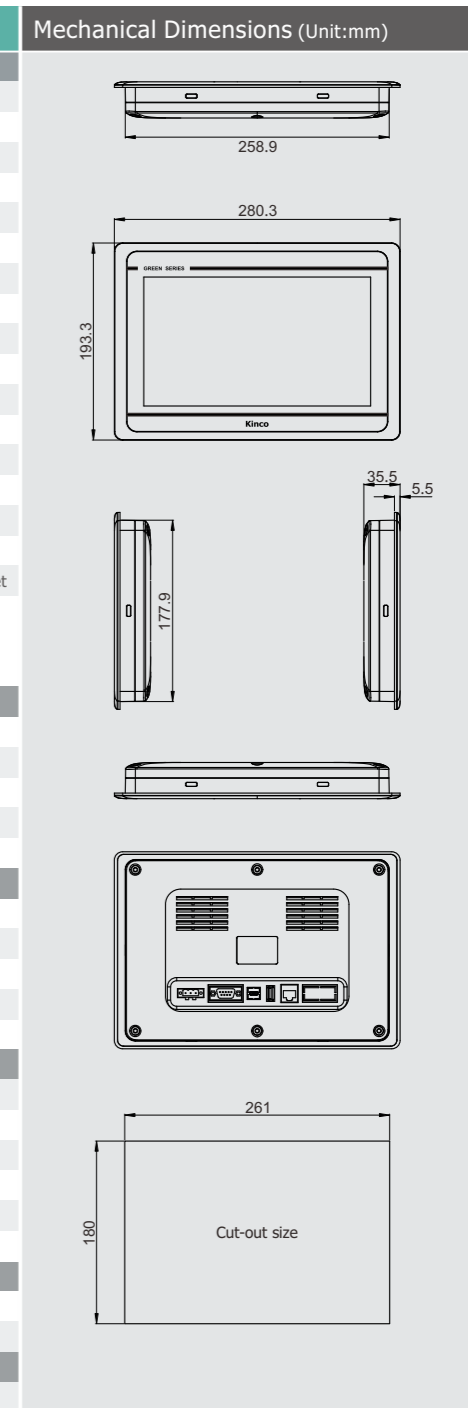

Note: GL100 is replacement of MT4532T. GL100E is replacement of MT4532TE.
Programming of MT4000 can be used for Green series HMI after edited by DTools.

GL Series 10.4"



GL104E

- Built-in isolated power supply to enhance reliability
- Industrial size 4:3, possessing great visual coordination
- Firm structure
- High cost-effective

Model	GL104E
Performance specification	
Display size	10.4"TFT
Display area	211.20mm(W)*158.40mm(H)
Resolution	800*600 pixels
Display color	16.7M true color
Display angle of view	70/70/60/70(left/right/up/down)
Contrast ratio	500:1
Backlight	LED
Brightness	350cd/m ²
Backlight life	More than 30000 hours
Touch panel	4 line precision resistance network (surface hardness 4H)
CPU	ARM RISC 32Bit 800MHz
Storage	128MB NAND Flash Memory+128MB DDR3 Memory
RTC	Built-in
Extensible memory	1 USB Host
Print port	USB Host/Serial port
Ethernet	10/100M self-adaption
Program download	USB Slave(Type B)/U disk/Ethernet
Communication port	COM0:RS232/RS485/RS422 COM2:RS232
Electrical specifications	
Input power supply	DC10.8V~DC28V, Built-in isolation power supply
Rated power	8W @24V DC
Allowable loss of power	<3ms
Insulation resistance	Over 50MΩ@500V DC
Hi-pot test	500 VAC 1 minute
Structure specifications	
PCB	None of spraying
Shell material	Engineering plastic
Shape size	310*230*56 mm
Cutout size	299*219 mm
Weight	1.715Kg
Environmental specifications	
Operating ambient temperature	0° C ~ 50° C
Operating ambient humidity	10% to 90% noncondensing
Storage ambient temperature	-20° C ~ 60° C
Storage ambient humidity	10% to 90% noncondensing
Sine vibration test	10~500Hz, 30m/s ² , X, Y, Z direction/hour
Cooling mode	Natural air cooling
Product certification	
Panel protection grade	Conforming to IP65 certification(4208-93)
CE authentication	EN61000-6-4:2007+A1:2011, EN61000-6-2:2005
Software	
Configuration software	Kinco DTools V3.3 and above

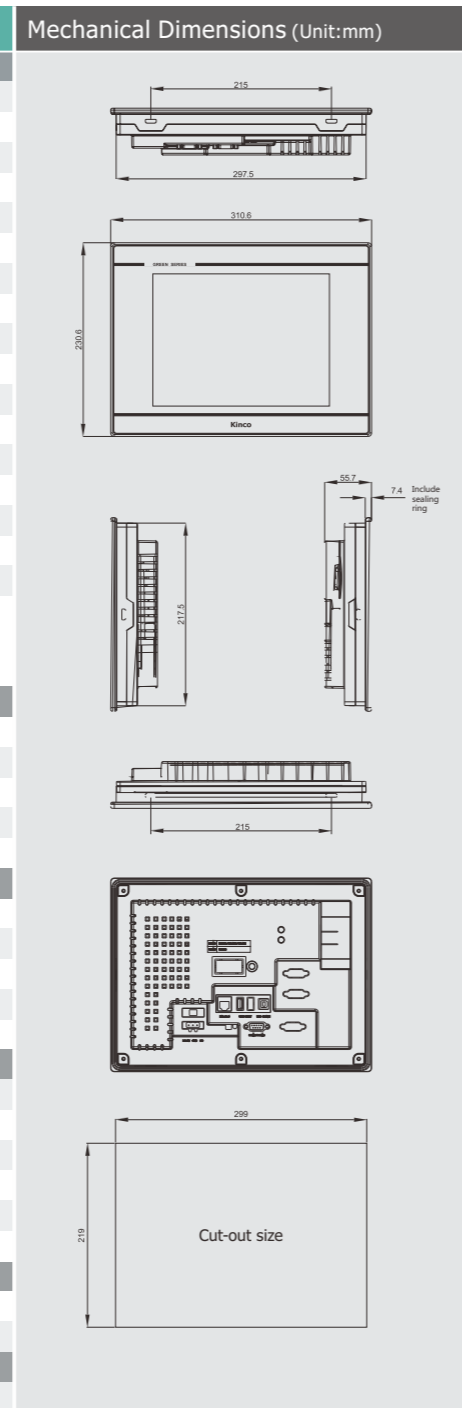

Note: GL104E is replacement of MT4513TE.
Programming of MT4000 can be used for Green series HMI after edited by DTools.

GL Series 15"



GL150E

- Preferred model for general use in 15 inch screen
- Built-in isolated power supply to enhance reliability
- Industrial size 4:3, possessing great visual coordination
- Firm structure

Model	GL150E
Performance specification	
Display size	15"TFT
Display area	304.13mm(W)*228.10mm(H)
Resolution	1024*768 pixels
Display color	65536 color
Display angle of view	80/80/80/80(left/right/up/down)
Contrast ratio	800:1
Backlight	LED
Brightness	420cd/m ²
Backlight life	More than 50000 hours
Touch panel	4 line precision resistance network (surface hardness 4H)
CPU	ARM RISC 32Bit 800MHz
Storage	128MB NAND Flash Memory+128MB DDR3 Memory
RTC	Built-in
Extensible memory	1 USB Host
Print port	USB Host/Serial port
Ethernet	10/100M self-adaption
Program download	USB Slave(Micro USB)/U disk/Ethernet
Communication port	COM0:RS232/RS485/RS422 COM2:RS232
Electrical specifications	
Input power supply	DC10.8V~DC28V, Built-in isolation power supply
Rated power	16W @24V DC
Allowable loss of power	<3ms
Insulation resistance	Over 50MΩ@500V DC
Hi-pot test	500 VAC 1 minute
Structure specifications	
PCB	None of spraying
Shell material	Engineering plastic
Shape size	398*298*47 mm
Cutout size	383*283 mm
Weight	3Kg
Environmental specifications	
Operating ambient temperature	-10° C ~ 55° C
Operating ambient humidity	10% to 90% noncondensing
Storage ambient temperature	-20° C ~ 60° C
Storage ambient humidity	10% to 90% noncondensing
Sine vibration test	10~500Hz, 30m/s ² , X, Y, Z direction/hour
Cooling mode	Natural air cooling
Product certification	
Panel protection grade	Conforming to IP65 certification(4208-93)
CE authentication	EN61000-6-4:2007+A1:2011, EN61000-6-2:2005
Software	
Configuration software	Kinco DTools V3.3 and above

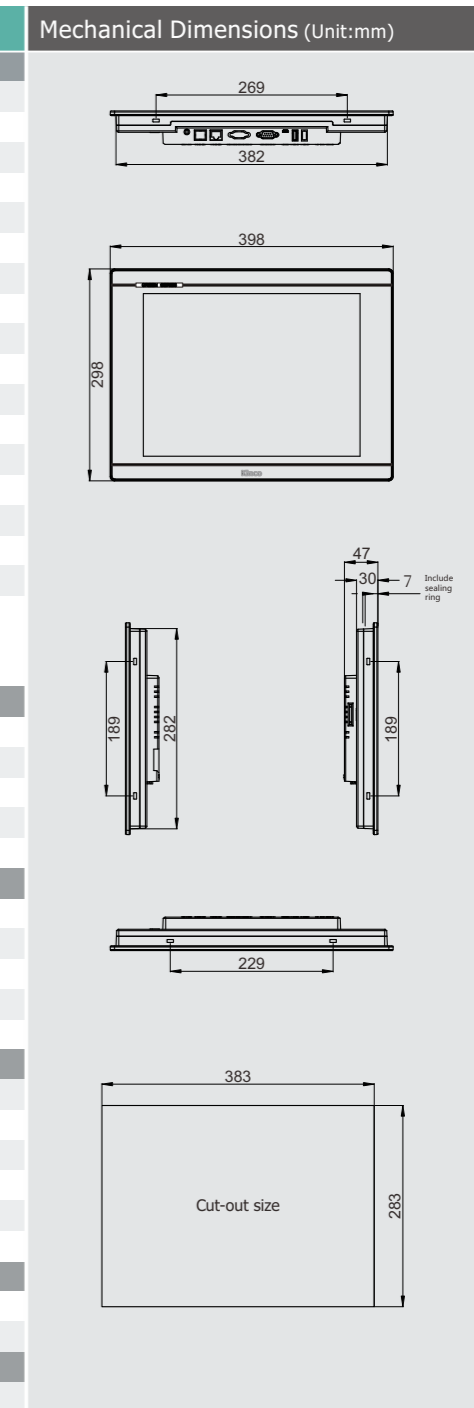

GT Series 7"

GT070E / GT070E-4G / GT070E-WiFi

- Support Ethernet, built-in 4G & WiFi
- Built-in Internet of Things function, support remote service
- HMI has the function of remote upload and download
- Remote transmission, PLC program upload, download, online debugging, desktop monitoring



Model	GT070E	GT070E-4G	GT070E-WiFi
Performance specification			
Display size	7" TFT		
Display area	154.08mm(W)*85.92mm(H)		
Resolution	800*480 pixels		
Display color	16.7M true color		
Display angle of view	70/70/50/70(left/right/up/down)		
Contrast ratio	500:1		
Backlight	LED		
Brightness	250cd/m ²		
Backlight life	More than 30000 hours		
Touch panel	4 line precision resistance network (surface hardness 4H)		
CPU	ARM RISC 32Bit 800MHz		
Storage	128MB NAND Flash Memory+128MB DDR3 Memory		
RTC	Built-in		
Extensible memory	1 USB Host		
Print port	USB Host/Serial port		
Internetwork	Ethernet	Ethernet/Cellular 2G/3G/4G	Ethernet/WiFi
Program download	USB Slave (Micro USB)/U disk/Ethernet		
Cellular and Wireless	None	LTE-FDD Band 1/3/5/8 LTE-TDD Band 38/39/40/41 UMTS Band 1/8 GSM Band 3/8	IEEE802.11 b/g/n 802.11b:max 17dBm 802.11g:max 17dBm 802.11n:max 17dBm
VPN	Support HMI remote upload and download and screen monitoring, support PLC passthrough program upload and download and online debugging		
Ethernet	10/100M self-adaption		
Communication port	COM0:RS232/RS485/RS422, COM2:RS232		
Electrical specifications			
Input power supply	DC10.8V~DC28V		
Rated power	4.2W @24V DC		
Allowable loss of power	<3ms		
Insulation resistance	Over 50MΩ@500V DC		
Hi-pot test	500 VAC 1 minute		
Structure specifications			
PCB	None of spraying		
Shell material	Engineering plastic		
Shape size	204*150*37 mm		
Cutout size	192*138 mm		
Weight	0.5Kg		
Environmental specifications			
Operating ambient temperature	0°C ~ 50°C		
Operating ambient humidity	10% to 90% noncondensing		
Storage ambient temperature	-20°C ~ 60°C		
Storage ambient humidity	10% to 90% noncondensing		
Sine vibration test	10~500Hz, 30m/s ² , X, Y, Z direction/hour		
Cooling mode	Natural air cooling		
Product certification			
Panel protection grade	Conforming to IP65 certification(4208-93)		
CE authentication	EN61000-6-4:2007+A1:2011, EN61000-6-2:2005		
Software			
Configuration software	Kinco DTools V3.5.0 and above		

Mechanical Dimensions (Unit:mm)

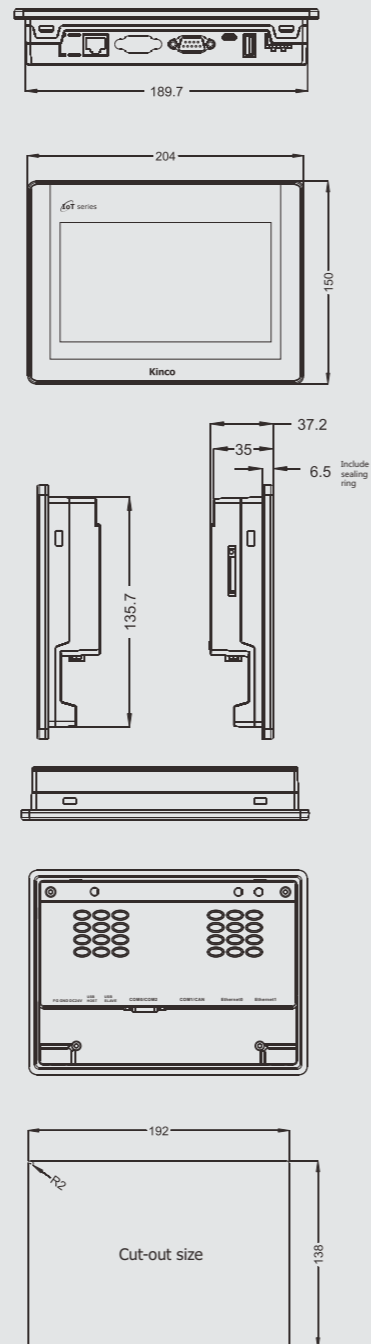

GT Series 7"

GT070HE / GT070HE-4G / GT070HE-WiFi

- 7",HD Display, 16.77 Million true colors
- Support Ethernet, built-in 4G / WiFi
- Edge computing is supported
- Built in Internet of things function, supporting remote service



Model	GT070HE	GT070HE-4G	GT070HE-WiFi
Performance specification			
Display size	7" TFT		
Display area	154.08mm(W)*85.92mm(H)		
Resolution	800*480 pixels		
Display color	16.7M true color		
Display angle of view	85/85/85/85(left/right/up/down)		
Contrast ratio	500:1		
Backlight	LED		
Brightness	450cd/m ²		
Backlight life	More than 30000 hours		
Touch panel	4 line precision resistance network (surface hardness 4H)		
CPU	ARM RISC 32Bit 800MHz		
Storage	128MB NAND Flash Memory+128MB DDR3 Memory		
RTC	Built-in		
Extensible memory	1 USB Host		
Print port	USB Host/Serial port		
Internetwork	Ethernet	Ethernet/Cellular 2G/3G/4G	Ethernet/WiFi
Program download	USB Slave (Micro USB)/U disk/Ethernet		
Cellular and Wireless	None	LTE-FDD Band 1/3/5/8 LTE-TDD Band 38/39/40/41 UMTS Band 1/8 GSM Band 3/8	IEEE802.11 b/g/n 802.11b:max 17dBm 802.11g:max 17dBm 802.11n:max 17dBm
VPN	Support HMI remote upload and download and screen monitoring, support PLC passthrough program upload and download and online debugging		
Ethernet	1*10/100M self-adaption		
Communication port	COM0:RS232/RS485/RS422, COM2:RS232		
Electrical specifications			
Input power supply	DC10.8V~DC28V		
Rated power	4.2W @24V DC		
Allowable loss of power	<3ms		
Insulation resistance	Over 50MΩ@500V DC		
Hi-pot test	500 VAC 1 minute		
Structure specifications			
PCB	None of spraying		
Shell material	Engineering plastic		
Shape size	204*150*37 mm		
Cutout size	192*138 mm		
Weight	0.5Kg		
Environmental specifications			
Operating ambient temperature	0°C ~ 50°C		
Operating ambient humidity	10% to 90% noncondensing		
Storage ambient temperature	-20°C ~ 60°C		
Storage ambient humidity	10% to 90% noncondensing		
Sine vibration test	10~500Hz, 30m/s ² , X, Y, Z direction/hour		
Cooling mode	Natural air cooling		
Product certification			
Panel protection grade	Conforming to IP65 certification(4208-93)		
CE authentication	EN61000-6-4:2007+A1:2011, EN61000-6-2:2005		
Software			
Configuration software	Kinco DTools V3.5.1 and above		

Mechanical Dimensions (Unit:mm)

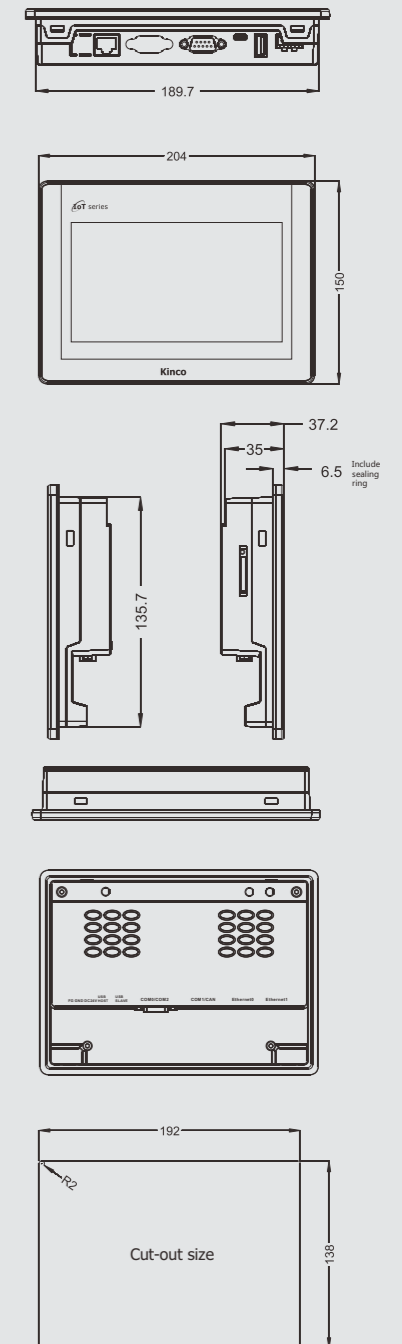

GT Series 10.1"

GT100E / GT100E-4G / GT100E-WiFi

- 10.1"HD display, 16.77M true color
- Support Ethernet, built-in 4G & WiFi
- Built-in Internet of Things function, support remote service
- Remote transmission, PLC program upload, download, online debugging, desktop monitoring

Model	GT100E	GT100E-4G	GT100E-WiFi
Performance specification			
Display size	10.1"TFT		
Display area	222.72(W)x125.28(H)		
Resolution	1024*600 pixels		
Display color	16.7M true color		
Display angle of view	85/85/85/85(left/right/up/down)		
Contrast ratio	500:1		
Backlight	LED		
Brightness	300cd/m ²		
Backlight life	More than 30000 hours		
Touch panel	4 line precision resistance network (surface hardness 4H)		
CPU	ARM RISC 32Bit 800MHz		
Storage	128MB NAND Flash Memory+128MB DDR3 Memory		
RTC	Built-in		
Extensible memory	1 USB Host		
Print port	USB Host/Serial port		
Internet network	Ethernet	Ethernet/Cellular 2G/3G/4G	Ethernet/WiFi
Program download	USB Slave (Micro USB)/U disk/Ethernet		
Cellular and Wireless	None	LTE-FDD Band 1/3/5/8 LTE-TDD Band 38/39/40/41 UMTS Band 1/8 GSM Band 3/8	IEEE802.11 b/g/n 802.11b:max 17dBm 802.11g:max 17dBm 802.11n:max 17dBm
VPN	Support HMI remote upload and download and screen monitoring, support PLC passthrough program upload and download and online debugging		
Ethernet	10/100M self-adaption		
Communication port	COM0:RS232/RS485/RS422, COM2:RS232		
Electrical specifications			
Input power supply	DC10.8V~DC28V		
Rated power	7W @24V DC		
Allowable loss of power	<3ms		
Insulation resistance	Over 50MΩ@500V DC		
Hi-pot test	500 VAC 1 minute		
Structure specifications			
PCB	None of spraying		
Shell material	Engineering plastic		
Shape size	271*213*38 mm		
Cutout size	260*202 mm		
Weight	1.1Kg		
Environmental specifications			
Operating ambient temperature	0° C ~ 50° C		
Operating ambient humidity	10% to 90% noncondensing		
Storage ambient temperature	-20° C ~ 60° C		
Storage ambient humidity	10% to 90% noncondensing		
Sine vibration test	10~500Hz, 30m/s ² , X, Y, Z direction/hour		
Cooling mode	Natural air cooling		
Product certification			
Panel protection grade	Conforming to IP65 certification(4208-93)		
CE authentication	EN61000-6-4:2007+A1:2011, EN61000-6-2:2005		
Software			
Configuration software	Kinco DTools V3.5.1 and above		

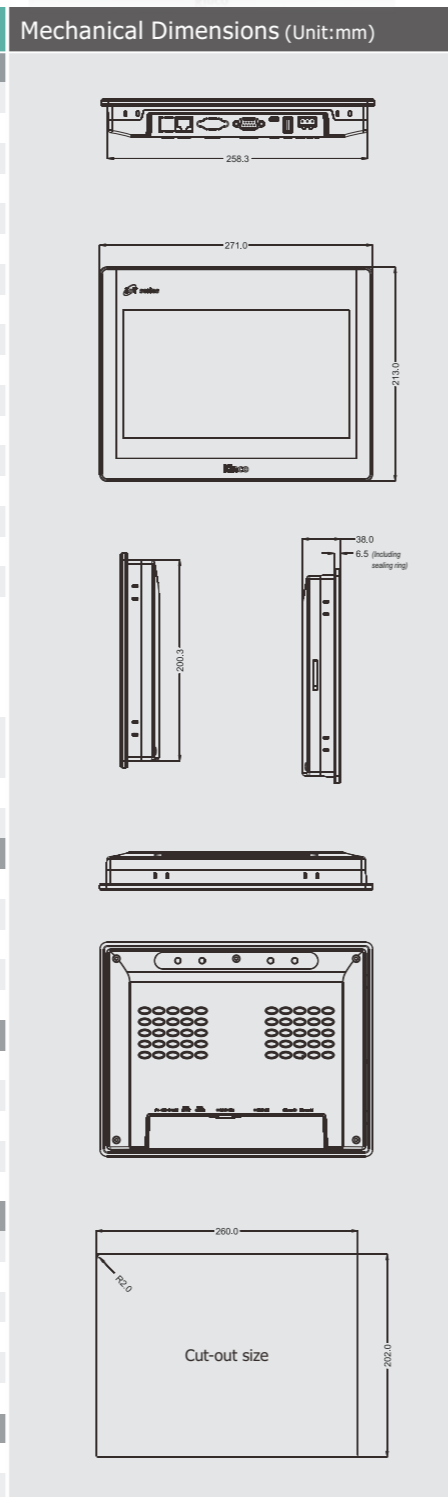

GT Series 10.1"

GT100E2

- 10.1"HD display, 16.77M true color
- Dual Ethernet port, 3 separated COM port
- Mainboard high technology protection
- Built-in power supply isolation, Powerful script function

Model	GT100E2
Performance specification	
Display size	10.1"TFT
Display area	222.72(W)x125.28(H)
Resolution	1024*600 pixels
Display color	16.7M true color
Display angle of view	70/70/60/60(left/right/up/down)
Contrast ratio	500:1
Backlight	LED
Brightness	350cd/m ²
Backlight life	More than 30000 hours
Touch panel	4 line precision resistance network (surface hardness 4H)
CPU	ARM RISC 32Bit 800MHz
Storage	256MB NAND Flash Memory+256MB DDR3 Memory
RTC	Built-in
Extensible memory	1 USB Host
Print port	USB Slave (Micro USB)/USB Host/Serial port
Network access	2 * Ethernet
Program download	USB Slave (Micro USB)/USB/Ethernet
VPN	Support HMI remote upload and download and screen monitoring, support PLC passthrough program upload, download and monitoring
Ethernet	2* 10/100M self-adaption port
Communication port	COM0:RS232/RS485/RS422, COM1:RS485/RS422, COM2:RS232
Electrical specifications	
Input power supply	DC10.8V~DC28V
Rated power	5W @24V DC
Allowable loss of power	<3ms
Insulation resistance	Over 50MΩ@500V DC
Hi-pot test	500 VAC 1 minute
Structure specifications	
PCB	Exquisite spraying
Shell material	Engineering plastic
Shape size	271*213*38 mm
Cutout size	260*202 mm
Weight	1.1Kg
Environmental specifications	
Operating ambient temperature	0° C ~ 50° C
Operating ambient humidity	10% to 90% noncondensing
Storage ambient temperature	-20° C ~ 60° C
Storage ambient humidity	10% to 90% noncondensing
Sine vibration test	10~500Hz, 30m/s ² , X, Y, Z direction/hour
Cooling mode	Natural air cooling
Product certification	
Panel protection grade	Conforming to IP65 certification(4208-93)
CE authentication	EN61000-6-4:2007+A1:2011, EN61000-6-2:2005
Software	
Configuration software	Kinco DTools V3.5.2 and above

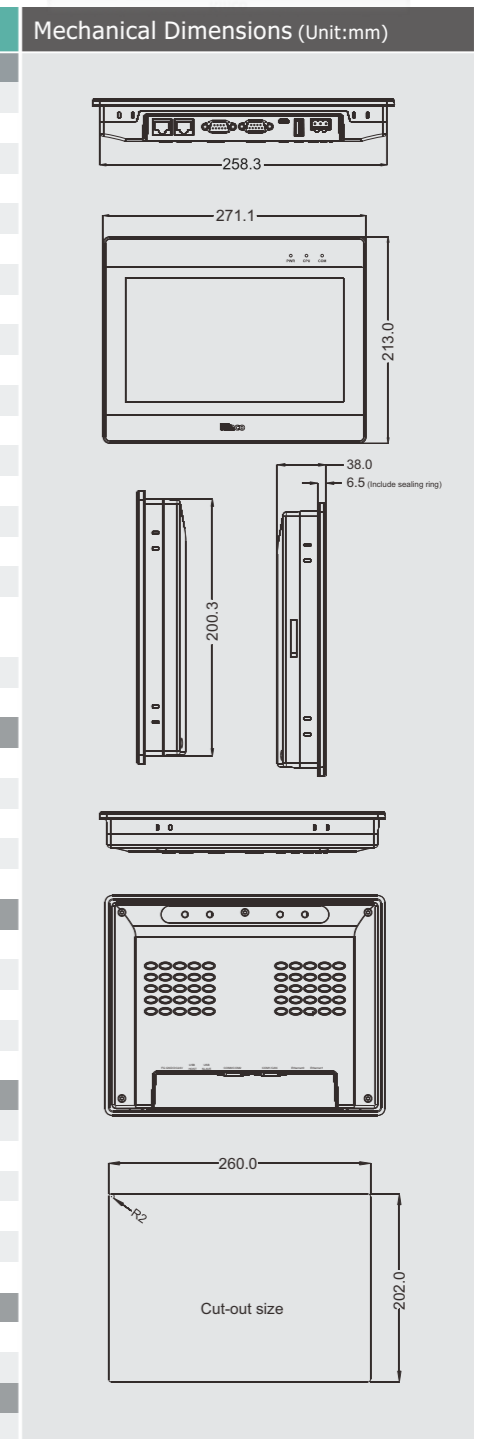

GW Series 15"

GW01 / GW01-4G / GW01-WiFi

- Freescale industrial-grade CPU, 800MHz processor, 128MB memory
- Dual-port ethernet + COM, can connect hundreds of mainstream controllers, no need to change the existing architecture
- Easy configuration, easy to achieve data mapping, the device data transfer to the cloud
- Free choice of wireless or 4G, suitable for different demand
- Small size, easy to install (DIN rail installation)



Model	GW01	GW01-4G	GW01-WiFi	Mechanical Dimensions (Unit:mm)
Performance specification				
CPU	ARM RISC 32Bit 800MHz			
Storage	128MB NAND Flash Memory+128MB DDR3 Memory			
RTC	Built-in			
Ethernet	2* 10/100M self-adaption			
WiFi	None	None	2.4GHz WiFi	
4G	None	Built-in	None	
USB	1*USB Slave (Micro USB)			
Program download	USB Slave(Micro USB)/ Ethernet	USB Slave(Micro USB)/ Ethernet	USB Slave(Micro USB)/ Ethernet/WiFi	
Cellular and Wireless	None	LTE-FDD Band 1/3/5/8 LTE-TDD Band 38/39/40/41 UMTS Band 1/8 GSM Band 3/8	IEEE802.11 b/g/n 802.11b:max 17dBm 802.11g:max 17dBm 802.11n:max 17dBm	
VPN	Support box remote upload and download and online monitoring, support PLC passthrough program upload and download and online debugging			
Communication port	COM0:RS232/RS485/RS422, COM2:RS232			
Electrical specifications				
Input power supply	DC12V~DC28V, Built-in isolation power supply			
Rated power	1.5W			
Allowable loss of power	<3ms			
Insulation resistance	Over 50MΩ@500V DC			
Hi-pot test	500 VAC 1 minute			
Structure specifications				
PCB	None of spraying			
Shell color	Black			
Shell material	Metallic			
Shape size	111.6*93.6*30 mm			
Installation	DIN-rail mounting (35mm)			
Weight	0.31Kg			
Environmental specifications				
Operating ambient temperature	-10° C ~ 55° C			
Operating ambient humidity	10% to 90% noncondensing			
Storage ambient temperature	-20° C ~ 60° C			
Storage ambient humidity	10% to 90% noncondensing			
Sine vibration test	10~500Hz, 30m/s ² , X, Y, Z direction/hour			
Cooling mode	Natural air cooling			
Product certification				
Panel protection grade	Conforming to IP20			
CE authentication	EN61000-6-4:2007+A1:2011, EN61000-6-2:2005			
Software				
Configuration software	Kinco DTools V3.4 and above			

FUTURE Series industrial HMI for High-end equipment industry

Kinco FUTURE series industrial HMI that balances the steady demands of industry with the enjoyment of new technologies. Strict material selection, innovative design, adhere to 10 years of ultra-long life cycle; Produced by Kinco intelligent manufacturing Center, the whole process of material and manufacturing can be traced to ensure high quality. Enjoy the new features of DTools configuration software; With the industry leading edge to create high-end equipment preferred products.



7 leading advantages for high-end equipment industry

- Powerful processor**
Industrial CPU, Frequency 1GHz

 - 1GHz Based on Cortex-A9
 - 512MB DDR3 Large memory
 - 4GB eMMC large capacity
- Support ethernet video monitoring**

Be the first to support webcams
Leading the new trend of industrial equipment video-based scene monitoring
The full series supports the ONVIF video interface standard
- High quality More stable**

 - Main board three anti - spray
 - Built-in isolated power supply
 - Pure PC material makes strong
 - Operating over a wide temperature range
 - Kinco intelligent manufacturing center production: whole-process quality tracking and monitoring
- Formula data free written**

Unique built-in ferroelectric memory allows frequent erasure
Important memory data is not lost, not down frequency, fast data reading and writing and power saving perfect combination
- Original industrial LCD screen**

 - Industrial LCD screen
 - 4:3 Large field of view
 - 88 degree wide viewing Angle
 - Wide temperature range: -30° C~80° C
- Standard audio output**

Make the equipment operating with color and sound
- Built-in IoT function**

 - Seamless docking Kinco M-IoT
 - Seamless docking Alibaba Cloud IIoT
 - Data cleaning edge calculation
 - Easy data to cloud
 - Remote download
 - Remote upload
 - Remote monitoring
 - PLC remote on-line debugging

F070E

- Cortex-A9 industrial-grade CPU, clocked at 1GHz, and memory up to 512M.
- 7", high brightness and high resolution display
- Built-in ferroelectric memory, supporting matching data without erasing a limited number of times.
- Three anti-spraying + isolated power supply to enhance reliability.
- Support network camera connection, real-time dynamic control.
- A new generation of Kinco DTools configuration software, powerful function, simple and easy



Model	F070E
Performance specification	
Display size	7" TFT
Resolution	800*480 pixels
Display color	16.7M true color
Backlight	LED
Brightness	400cd/m ²
Backlight life	More than 30000 hours
Touch panel	4 line precision resistance network (surface hardness 4H)
CPU	32Bit RISC Cortex-A9 1GHZ
Storage	512MB DDR3 + 8GB eMMC
RTC	Built-in + 32KB
Extensible memory	USB Host
Print port	USB/serial port
Ethernet	1*10/100M self-adaption
Program download	Serial port/USB/Ethernet
Communication port	COM0:RS232/RS485/RS422 COM1:RS232/RS485/RS422 COM2:RS232
Audio output	1*Audio output
Extended interface	None
Electrical specifications	
Input power supply	DC12V~DC28V, Built-in isolation power supply
Rated power	5W
Allowable loss of power	<3ms
Insulation resistance	Over 50MΩ@500V DC
Hi-pot test	500 VAC 1 minute
Structure specifications	
PCB	Exquisite spraying
Shell color	Light gray
Shell material	Engineering plastic
Shape size	204*150*37.2 mm
Cutout size	192*138 mm
Weight	0.57Kg
Environmental specifications	
Operating ambient temperature	-10° C ~ 55° C
Operating ambient humidity	10% to 90% noncondensing
Storage ambient temperature	-20° C ~ 60° C
Storage ambient humidity	10% to 90% noncondensing
Sine vibration test	10~500Hz, 30m/s ² , X, Y, Z direction/hour
Cooling mode	Natural air cooling
Product certification	
Panel protection grade	Conforming to IP65
CE authentication	Conforming to CE
Software	
Configuration software	Kinco DTools V3.5.1 and above

尺寸图(单位:mm)

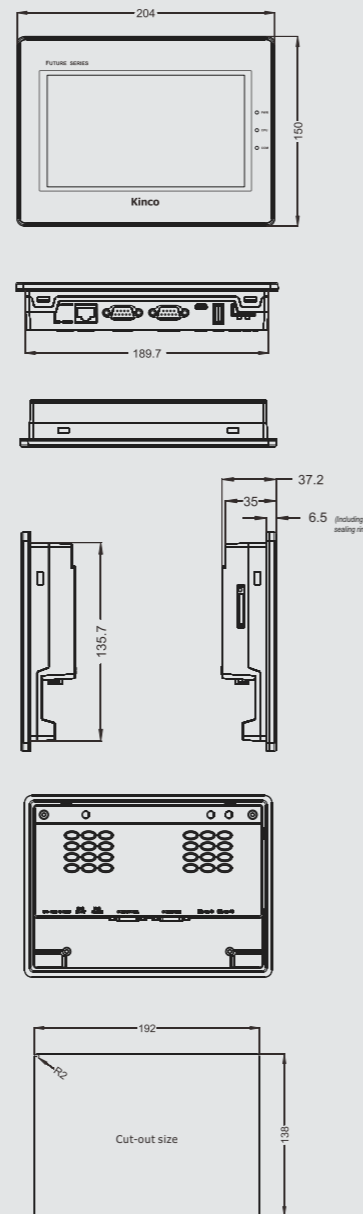

F080E

- Cortex-A9 industrial-grade CPU, clocked at 1GHz, and memory up to 512M.
- 8", high brightness and high resolution display, 4:3 business size.
- Built-in ferroelectric memory, supporting matching data without erasing a limited number of times.
- Three anti-spraying + isolated power supply to enhance reliability.
- SD card expansion storage space.
- Support network camera connection, real-time dynamic control.
- Support MPI 187.5K.



Model	F080E
Performance specification	
Display size	8" TFT
Resolution	800*600 pixels
Display color	16.7M true color
Backlight	LED
Brightness	250cd/m ²
Backlight life	More than 30000 hours
Touch panel	4 line precision resistance network (surface hardness 4H)
CPU	32Bit RISC Cortex-A9 1GHZ
Storage	512MB DDR3 + 4GB eMMC
RTC	Built-in + 32KB
Extensible memory	2 USB Host + 1SD Card
Print port	USB Host/serial port
Ethernet	10/100M self-adaption
Program download	U disk/Ethernet
Communication port	COM0:RS232/RS485/RS422 COM1:RS232/RS485/RS422 COM2:RS232
Audio output	1*Audio output
Extended interface	None
Electrical specifications	
Input power supply	DC12V~DC28V, Built-in isolation power supply
Rated power	8W @24V DC
Allowable loss of power	<3ms
Insulation resistance	Over 50MΩ@500V DC
Hi-pot test	500 VAC 1 minute
Structure specifications	
PCB	Exquisite spraying
Shell color	Beige white
Shell material	Engineering plastic
Shape size	235*172*57.9 mm
Cutout size	224*161 mm
Weight	1.3Kg
Environmental specifications	
Operating ambient temperature	-10° C ~ 55° C
Operating ambient humidity	10% to 90% noncondensing
Storage ambient temperature	-20° C ~ 60° C
Storage ambient humidity	10% to 90% noncondensing
Sine vibration test	10~500Hz, 30m/s ² , X, Y, Z direction/hour
Cooling mode	Natural air cooling
Product certification	
Panel protection grade	Conforming to IP65 certification(4208-93)
CE authentication	EN61000-6-4:2007+A1:2011, EN61000-6-2:2005
Software	
Configuration software	Kinco DTools V3.4 and above

Mechanical Dimensions (Unit:mm)

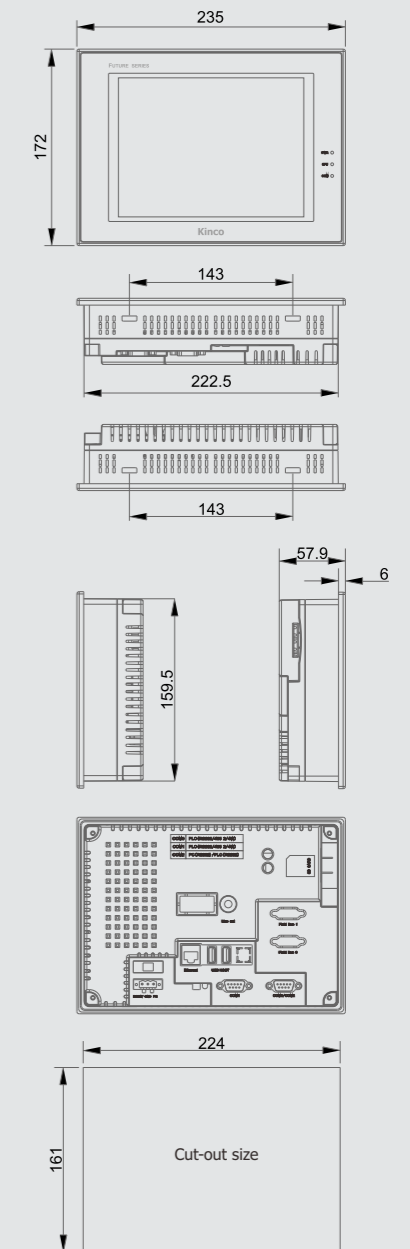

F104E/F104E-CAN

- Cortex-A9 industrial-grade CPU, clocked at 1GHz, and memory up to 512M;
- 10.4", high brightness and high resolution display, 4: 3 business size;
- Built-in ferroelectric memory, supporting matching data without erasing a limited number of times;
- Three anti-spraying + isolated power supply to enhance reliability;
- SD card expansion storage space;
- Support network camera connection, real-time dynamic control;
- Support MPI 187.5K.



Model	F104E	F104E-CAN
Performance specification		
Display size	10.4" TFT	
Resolution	1024*768 pixels	
Display color	16.7M true color	
Backlight	LED	
Brightness	450cd/m ²	
Backlight life	More than 50000 hours	
Touch panel	4 line precision resistance network (surface hardness 4H)	
CPU	32Bit RISC Cortex-A9 1GHz	
Storage	512MB DDR3 + 4GB eMMC	
RTC	Built-in + 32KB	
Extensible memory	2 USB Host + 1SD Card	
Print port	USB Host/serial port	
Ethernet	10/100M self-adaption	
Program download	U disk/Ethernet	
Communication port	COM0:RS232/RS485/RS422 COM1:RS232/RS485/RS422 COM2:RS232	
Audio output	1*Audio output	
Extended interface	None	1*CANopen
Electrical specifications		
Input power supply	DC12V~DC28V, Built-in isolation power supply	
Rated power	12W @24V DC	
Allowable loss of power	<3ms	
Insulation resistance	Over 50MΩ@500V DC	
Hi-pot test	500 VAC 1 minute	
Structure specifications		
PCB	Exquisite spraying	
Shell color	Beige white	
Shell material	Engineering plastic	
Shape size	310.6*230.6*55.7 mm	
Cutout size	299*219 mm	
Weight	1.7Kg	
Environmental specifications		
Operating ambient temperature	-10° C ~ 50° C	
Operating ambient humidity	10% to 90% noncondensing	
Storage ambient temperature	-20° C ~ 60° C	
Storage ambient humidity	10% to 90% noncondensing	
Sine vibration test	10~500Hz, 30m/s ² , X, Y, Z direction/hour	
Cooling mode	Natural air cooling	
Product certification		
Panel protection grade	Conforming to IP65 certification(4208-93)	
CE authentication	EN61000-6-4:2007+A1:2011, EN61000-6-2:2005	
Software		
Configuration software	Kinco DTools V3.4 and above	

尺寸图(单位:mm)

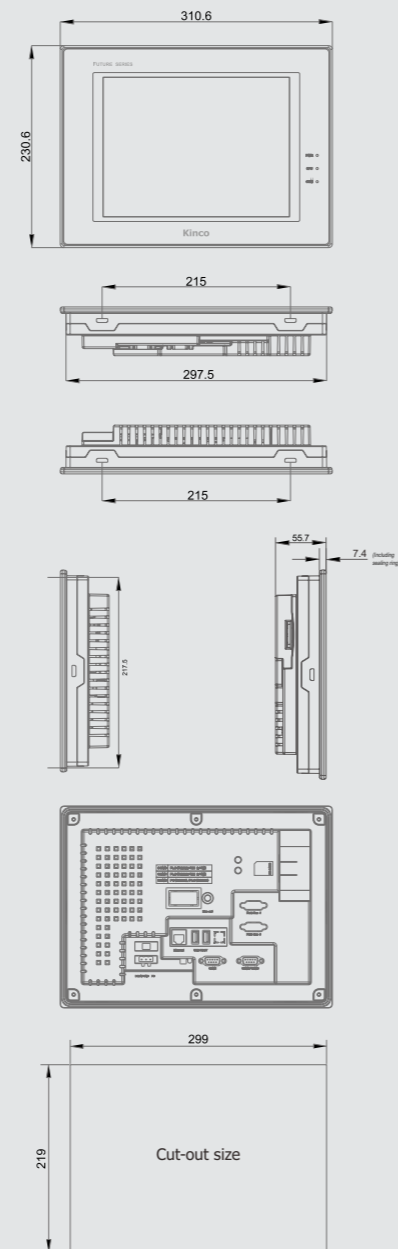

F150E

- Cortex-A9 industrial-grade CPU, clocked at 1GHz, and memory up to 512M.
- 15", high brightness and high resolution display, 4:3 business size.
- Built-in ferroelectric memory, supporting matching data without erasing a limited number of times.
- SD card expansion storage space.
- Support network camera connection, real-time dynamic control.
- Support MPI 187.5K.



Model	F150E
Performance specification	
Display size	15" TFT
Resolution	1024*768 pixels
Display color	16.7M true color
Backlight	LED
Brightness	300cd/m ²
Backlight life	More than 50000 hours
Touch panel	4 line precision resistance network (surface hardness 4H)
CPU	32Bit RISC Cortex-A9 1GHz
Storage	512MB DDR3 + 4GB eMMC
RTC	Built-in + 32KB
Extensible memory	2 USB Host + 1SD Card
Print port	USB Host/serial port
Ethernet	10/100M self-adaption
Program download	Serial port/USB Host/Ethernet
Communication port	COM0:RS232/RS485/RS422 COM1:RS232/RS485/RS422 COM2:RS232
Audio output	1*Audio output
Extended interface	1*CANopen
Electrical specifications	
Input power supply	DC12V~DC28V, Built-in isolation power supply
Rated power	12W @24V DC
Allowable loss of power	<3ms
Insulation resistance	Over 50MΩ@500V DC
Hi-pot test	500 VAC 1 minute
Structure specifications	
PCB	Exquisite spraying
Shell color	Black
Shell material	Metallic
Shape size	406.5*313.5*48.3 mm
Cutout size	387.5*294.5 mm
Weight	5Kg
Environmental specifications	
Operating ambient temperature	-10° C ~ 50° C
Operating ambient humidity	10% to 90% noncondensing
Storage ambient temperature	-20° C ~ 60° C
Storage ambient humidity	10% to 90% noncondensing
Sine vibration test	10~500Hz, 30m/s ² , X, Y, Z direction/hour
Cooling mode	Natural air cooling
Product certification	
Panel protection grade	Conforming to IP65 certification(4208-93)
CE authentication	EN61000-6-4:2007+A1:2011, EN61000-6-2:2005
Software	
Configuration software	Kinco DTools V3.5 and above

Mechanical Dimensions (Unit:mm)

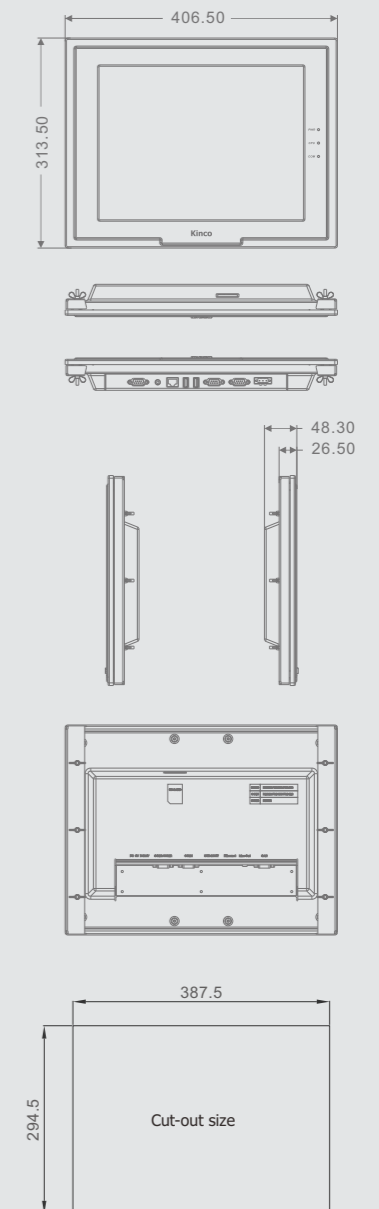

xF-SiHMI01 Split type industrial HMI

- High-end configuration: Cortex-A9 architecture, primary frequency is 1G, 512MB DDR3 +4GB eMMC.
- HDMI V1.4 Full HD(1920*1080@60Hz) high-resolution output.
- Standard with 2 USB hosts, 3 serial ports (COM1 is the type of terminal interface), one network port.
- The concept of separating the screen from the host, adapting various display devices, such as TV, monitor, projector, etc., through HDMI interface.
- 2-channel digital input (programmable, standard 24V source), 3-channel digital output (programmable, standard 24V source).
- Optional WiFi 802.11b /g/ N wireless network, SD card to expand storage capacity.
- Various installation methods: DIN rail installation (35mm), VESA rack installation (75*75mm).



Model	xF-SiHMI01	尺寸图(单位:mm)
Performance specification		
CPU	32Bit RISC Cortex-A9 1GHz	
Storage	512MB DDR3 + 4GB eMMC	
Interface Configuration		
Display port	1*HDMI V1.4 Full HD (1920*1080@60Hz)	
Extensible memory	2*USB Host	
Ethernet	10/100M self-adaption	
Communication port	COM0:RS232/RS485/RS422 COM1:RS485 COM2:RS232	
I/O	2 channel digital input (programmable, standard 24V source) 3 channel digital output (programmable, standard 24V source)	
Output power supply	1*DC 24V power supply (same input voltage), current 500mA	
Electrical specifications		
Rated power	2.4W	
Rated voltage	DC 24V	
Allowable loss of power	<3ms	
Insulation resistance	Over 50MΩ@500V DC	
Hi-pot test	500 VAC 1 minute	
Structure specifications		
PCB	None of spraying	
Shell color	Black	
Shell material	Metallic	
Shape size	113*104*30.2 mm	
Installation	DIN rail installation (35mm) VESA rack installation (75*75mm)	
Weight	0.47Kg	
Environmental specifications		
Operating ambient temperature	0° C ~ 50° C	
Operating ambient humidity	10% to 90% noncondensing	
Storage ambient temperature	-30° C ~ 80° C	
Storage ambient humidity	10% to 90% noncondensing	
Sine vibration test	10~500Hz, 30m/s², X, Y, Z direction/hour	
Cooling mode	Natural air cooling	
Product certification		
Panel protection grade	IP20	
CE authentication	EN61000-6-4:2007+A1:2011, EN61000-6-2:2005	

GR series Rear installation without front shell

The rear-installation fixation method can perfectly fit the surface of the equipment and be integrated with the equipment.



Model	GR043	GR070E	GR100E
Performance specification			
Display size	4.3"TFT	7"TFT	10.1"TFT
Resolution	480*272 pixels	800*480 pixels	1024*600 pixels
Display color		16.7M true color	
Brightness	450cd/m²	250cd/m²	400cd/m²
Backlight		LED	
Backlight life		More than 30000 hours	
Touch panel		4 line precision resistance network (surface hardness 4H)	
CPU		ARM RISC 32Bit 800MHz	
Storage		128MB NAND Flash Memory+128MB DDR3 Memory	
RTC		Built-in	
Extensible memory		1 USB Host	
Print port		USB Host/serial port	
Ethernet	None	10/100M self-adaption	
Program download	USB Slave(Micro USB)/U disk	USB Slave(Micro USB)/U disk/Ethernet	
Communication port	COM0:RS232/RS485/RS422 COM2:RS232	COM0:RS232/RS485/RS422 COM2:RS232	
Electrical specifications			
Input power supply		DC10.8V~DC28V	
Rated power	2W @24V DC	3.6W @24V DC	6W @24V DC
Allowable loss of power		<3ms	
Insulation resistance		Over 50MΩ@500V DC	
Hi-pot test		500 VAC 1 minute	
Structure specifications			
PCB		None of spraying	
Shell color		-	Metallic gray
Shell material		Metallic	
Shape size	128×75×27mm	190.4*110*30 mm	275.6×163.6×32mm
Cutout size	107.7×69.4 mm	166.7*101.6 mm	236.9×146.3 mm
Weight	0.2Kg	0.3Kg	0.9Kg
Environmental specifications			
Operating ambient temperature		0° C ~ 50° C	
Operating ambient humidity		10% to 90% noncondensing	
Storage ambient temperature		-20° C ~ 60° C	
Storage ambient humidity		10% to 90% noncondensing	
Sine vibration test		10~500Hz, 30m/s², X, Y, Z direction/hour	
Cooling mode		Natural air cooling	
Product certification			
Panel protection grade		Conforming to IP20 certification	
CE authentication		EN61000-6-4:2007+A1:2011, EN61000-6-2:2005	

SZ7G Series handheld terminal

- Basic specification: 7" TFT, 800x480 pixels, 16.7M true color.
- Standard configuration: 3-option switch, emergency stop switch, holding switch, 10 custom buttons, 2 indicators.
- Practical design: both buttons and touch control, more applications, more flexible choices.
- Mobile operation: handheld terminal, standard with 5 meters of cable.
- Various installation methods, such as suspension, scaffolding, etc.



Model	SZ7G	SZ7GS	SZ7GE	SZ7GES	Mechanical Dimensions (Unit:mm)
Performance specification					
Display size	7" TFT				
Resolution	800*480 pixels				
Display color	16.7M true color				
Brightness	250cd/m ²				
Backlight	LED				
Touch panel	4 line precision resistance network (surface hardness 4H)				
Backlight life	50000 hours				
Programable button	10				
Programable LED	2				
Emergency button	1				
Selection switch	1				
Handhold switch	None	1	None	1	
Processor	ARM RISC 32bit 800MHz				
Memory	128MB NAND Flash +128MB DDR3 RAM				
RTC	Built-in				
Expandable memory	1 USB Host				
Ethernet	None				10M/100M self-adaptive
Program download	Serial port/U disk		U disk/Ethernet		
COM port	COM1:RS485, COM0:RS232		Ethernet		
Electrical specifications					
Input power supply	DC16~32V, Built-in isolation power supply				
Rated power	8W@DC24V				
Power down allowed	<3ms				
Insulation resistance	Over 50MΩ@500V DC				
Dielectric strength test	500V AC 1 minute				
Cable length	5 m				
Structure specifications					
PCB	None of spraying				
Shell color	Black				
Shell material	Engineering plastic				
Dimensions	220*156*45 mm				
Installation	Bracket mounting, suspension mounting				
Environmental specifications					
Operating temperature	0° C ~ 50° C				
Operating humidity	10% to 90% noncondensing				
Storage temperature	-10° C ~ 60° C				
Storage humidity	10% to 90% noncondensing				
Sine vibration test	10~500Hz, 30m/s ² , X, Y, Z direction/hour				
Cooling mode	Natural air cooling				
Product certification					
Degree of protection	Front panel IP65,overall unit IP62				
CE authentication	EN61000-6-4:2007+A1:2011, EN61000-6-2:2005				
Software					
Configuration software	Kinco DTools V3.4.3 and above				

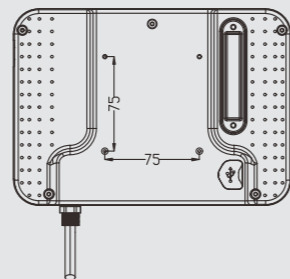
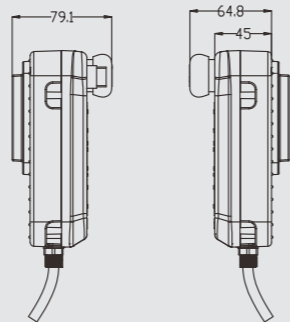
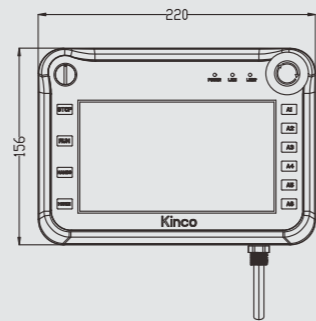
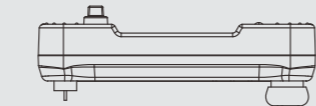

CZ6 Designed for use in severe environments

- Outer shell use high thermostability,high intensity,anti-uvioresistant material ensure the best performance when HMI working in the severe environment.
- With wide range temperature LCD,working temperature can be -20° C - 60° C.
- Highly shockproof performance.
- Multiple serial ports,CAN port,support CANopen/CAN1939/serials port/RS232/RS485.
- Whole body IP65 protection.



Model	CZ6	Mechanical Dimensions (Unit:mm)
Performance specification		
Display	5.7" TFT	
Resolution	640*480 pixels	
Color	65536 colors	
Brightness	700cd/m ²	
Backlight	LED	
Backlight life	50000 hrs	
Processor	RISC Cortex-A8 800MHz	
Memory	256MB Flash + 256MB DDR3	
RTC	Built-in	
Expandable memory	1 USB Host	
Print port	USB/serial port	
Ethernet	None	
Program download	1*USB 2.0/Serial port	
COM port	COM0: RS485, COM2: RS232, 1*CANopen	
Extended interface	None	
Electrical specifications		
Input range	DC9V~DC36V	
Rated power	10W@DC24V (Isolation)	
Power down allowed	<3ms	
Insulation resistance	Over 50MΩ@500V DC	
Dielectric strength test	500V AC 1 minute	
Structure specifications		
PCB	None of spraying	
Shell color	Navy blue	
Shell material	Engineering plastic	
Dimensions	180.3*133.9*70.7 mm	
Cutout size	171*125mm	
Weight	1Kg	
Environmental specifications		
Operating temperature	-20° C ~ 60° C	
Operating humidity	10% to 90% noncondensing	
Storage temperature	-30° C ~ 80° C	
Storage humidity	10% to 90% noncondensing	
Sine vibration test	10~500Hz, 30m/s ² , X, Y, Z direction/hour	
Cooling mode	Natural air cooling	
Product certification		
Degree of protection	IP65 (whole body)	
CE authentication	EN61000-6-4:2007+A1:2011, EN61000-6-2:2005	
Software		
Configuration software	Kinco DTools V3.3 and above	

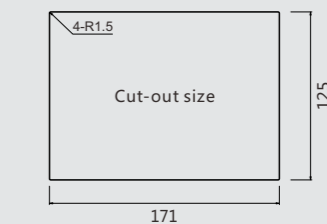
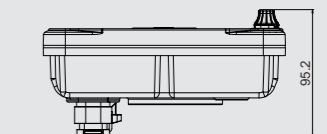
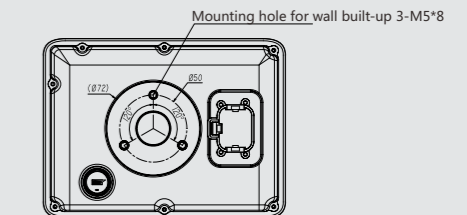
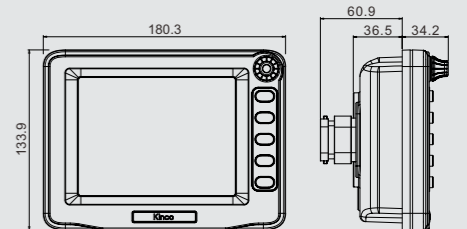

CZ10 Customized HMI for vehicle

- RISC Cortex-A8 800MHz CPU, faster and smoother.
- Large capacity, 256MB FLASH+256MB DDR3 RAM.
- Double CAN port design, support CANopen/CANJ1939.
- Double serial port extension, support RS232/485/422.
- Double video input, perfect for multi-channel monitoring.
- The buttons are equipped with adaptive backlight lighting, so that operation at night can be clearly seen.
- Wide temperature industrial-grade liquid crystal, working temperature -20° C ~ 70° C, full Angle of view, high brightness, visible under sunlight.
- All-metal structure body, better heat dissipation performance, better anti-vibration and anti-interference ability.
- Dual isolation circuit for power supply and serial port to minimize fault, downtime and additional service costs caused by interference.



Model	CZ10	Mechanical Dimensions (Unit:mm)
Performance specification		
Display	10.4 " TFT	
Resolution	640*480 pixel	
Color	65536 colors	
Brightness	500cd/m ²	
Backlight	LED	
Backlight life	50000 hrs	
Touch panel	None	
Funtion keys	16 keys, programmable functions can be customized	
Processor	RISC Cortex-A8 800MHz	
Memory	256MB Flash + 256MB RAM	
RTC	Built-in	
Expandable memory	1 USB Host (Max 16G)	
Print port	USB Host/Slave/serial port	
Program download	1*USB 2.0/Serial port	
COM port	2*CAN,1*RS232/RS485/RS422,1*RS232(isolation)	
Video input	2*CVBS analog signal input(BNC connector) support PAL/NTSC format	
Electrical specifications		
Power supply isolation	Built-in	
Rated power	12W	
Rated voltage	DC 24V	
Input range	DC9V~36V	
Power down allowed	<3ms	
Insulation resistance	Over 50MΩ@500V DC	
Dielectric strength test	500V AC 1 minute	
Structure specifications		
PCB	None of spraying	
Shell color	Brown	
Shell material	Aluminum alloy	
Dimensions	300*226*70 mm	
Cutout size	281*207 mm	
Weight	3.3Kg	
Environmental specifications		
Operating temperature	-20° C ~ 70° C	
Operating humidity	10% to 90% noncondensing	
Storage temperature	-30° C ~ 80° C	
Storage humidity	10% to 90% noncondensing	
Sine vibration test	10~500Hz, 30m/s ² , X, Y, Z direction/hour	
Cooling mode	Natural air cooling	
Product certification		
Degree of protection	IP65(4280-93)	
CE authentication	EN61000-6-4:2007+A1:2011, EN61000-6-2:2005	
Software		
Configuration software	Kinco DTools V3.3 and above	

Configuration Software : Kinco DTools



Kinco DTools configuration software. Support simplified Chinese, Chinese, English, Korean, German, Russian, Turkish, Arabic and other eight language versions. Configuration design content supports all installed fonts on your computer system. Support remote cloud monitoring, VNC supports terminal interoperation from screen to screen or screen to PC and mobile phone etc, support installment, PDF browsing, operation log and other convenient control design wizard guide interface, humanized design, what you see is what you get, you can get started quickly.

IoT function
Manufacturers or Users

different Settings channel to collect different data

Remote service

Remote desktop, remote penetration
remote download

Multi-level event display

Be the first to report the priority event

Free upload or download of files

FTP Client - recipe area browsing, and external storage device file transfer

Unified register address management

Centralized management of the use of various registers, can directly jump to the corresponding screen

Dynamic generation of QR code

Express the content to be expressed in the form of QR code, such as payment demand

U-disk automatic import project

The same project multi-screen download necessary

Level password management

16 levels users set
Different screen can be seen by using different passwords

User-privilege management

Different display by different user or permissions, convenient for multi-user management

CSV File encrypted export

Improve the confidentiality of historical data, recipes, operational logs, events and other CSV file data